

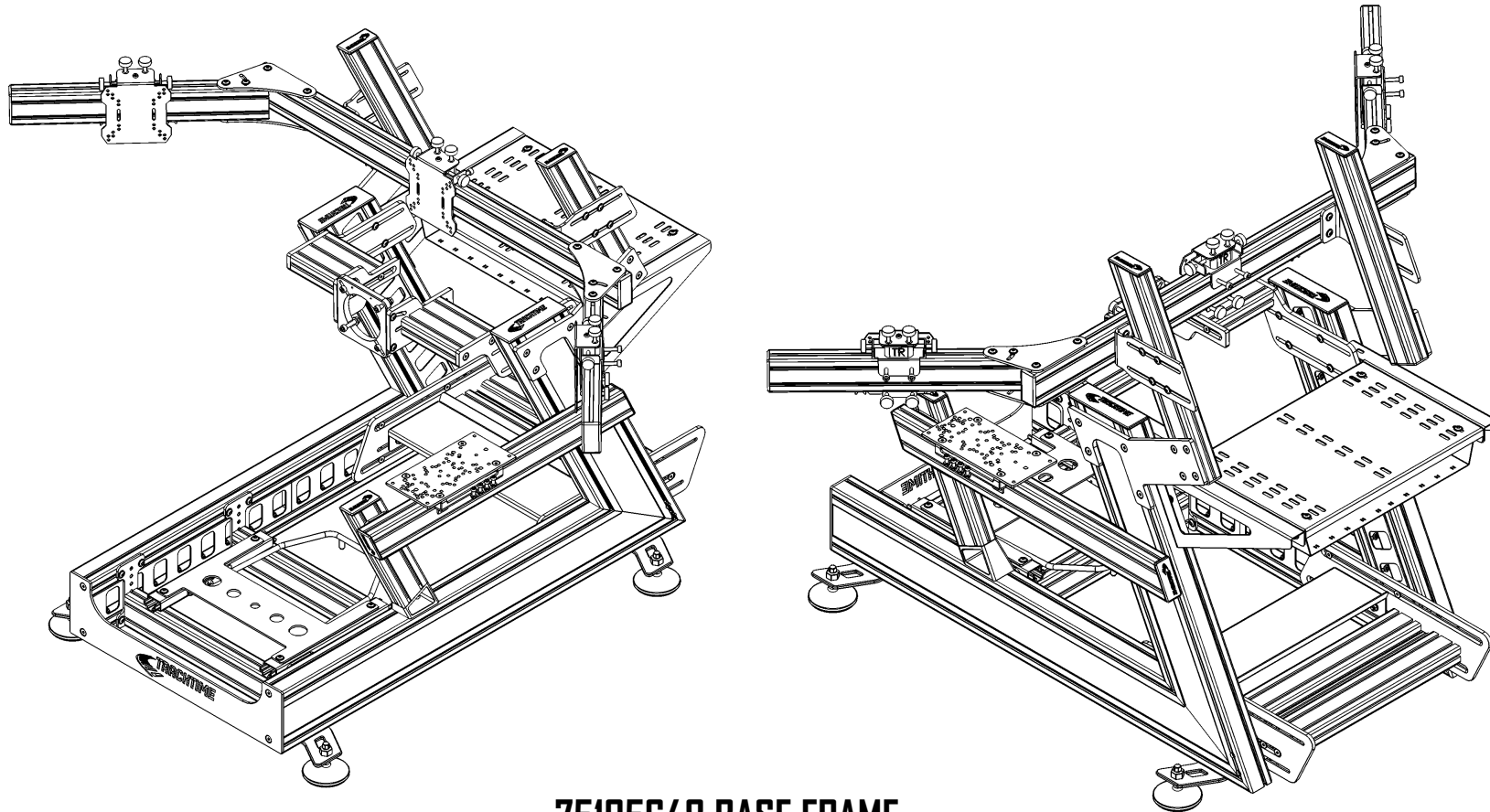

series / pne



75105648 BASE FRAME

Version 2.2

BEFORE STARTING THE BUILD

The following are needed for assembly:

- Soft base / underlay (scratch protection)
- A set of hex wrenches
- Ratchet with 13mm nut
- 24mm Open End Wrench or adjustable Wrench
- Rubber Mallet
- Tape measure /ruler
- Scissors
- A buddy who can lend a hand

Read the manual first. All remarks are important and could help you avoid problems.

Use BOM (Bill of Material) to find the sizes and lengths of the parts.



BEFORE STARTING THE BUILD

NOTE: This kit includes an additional bag of replacement screws.

You receive two screw packs with the 75105648 Baseframe kit.

One pack contains the **regular non-oily screws**, while the other contains **oily spare screws**.

The oily screws included in the 75105648 Baseframe kit are **replacement screws only** and should be used **only if** the required screws from the main screw pack are not sufficient.

If necessary, end caps and T-nuts can be cleaned with isopropanol.



The screws supplied with the **pedal unit** and the **wheel mount** can be used **out of the box**.

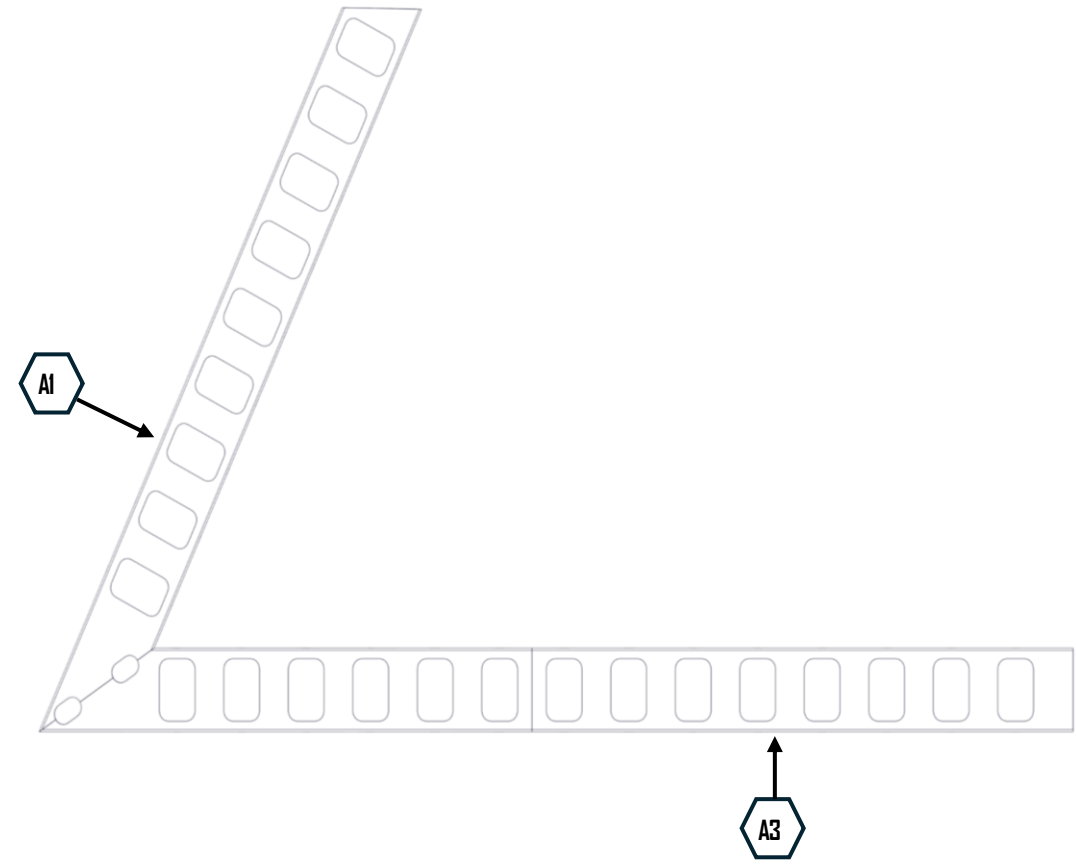

TABLE OF CONTENT

1.	Baseframe	4
2.	Wheel unit - Baseframe parts	21
3.	Wheel unit – Frontmount solution	22
4.	Wheel unit – Topmount solution	25
5.	Pedal unit	28
6.	Wheel deck compatibility	34

Arrange the (A1) Baseangle +(A3) Baseprofile on a flat, protected and soft surface

- 1x A3 
- 1x A1 



RIGHT Side

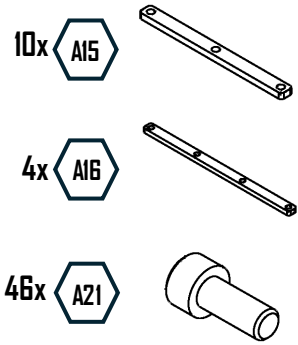

Only fasten the (A21) M8x12 screws by one turn so that the T-nut can slide into the aluminium profiles.

Use the outer holes in (A1) and (A3).

Please wrap some electrical tape around the allen key where it could get in contact with the Frame parts. That will protect the surface.

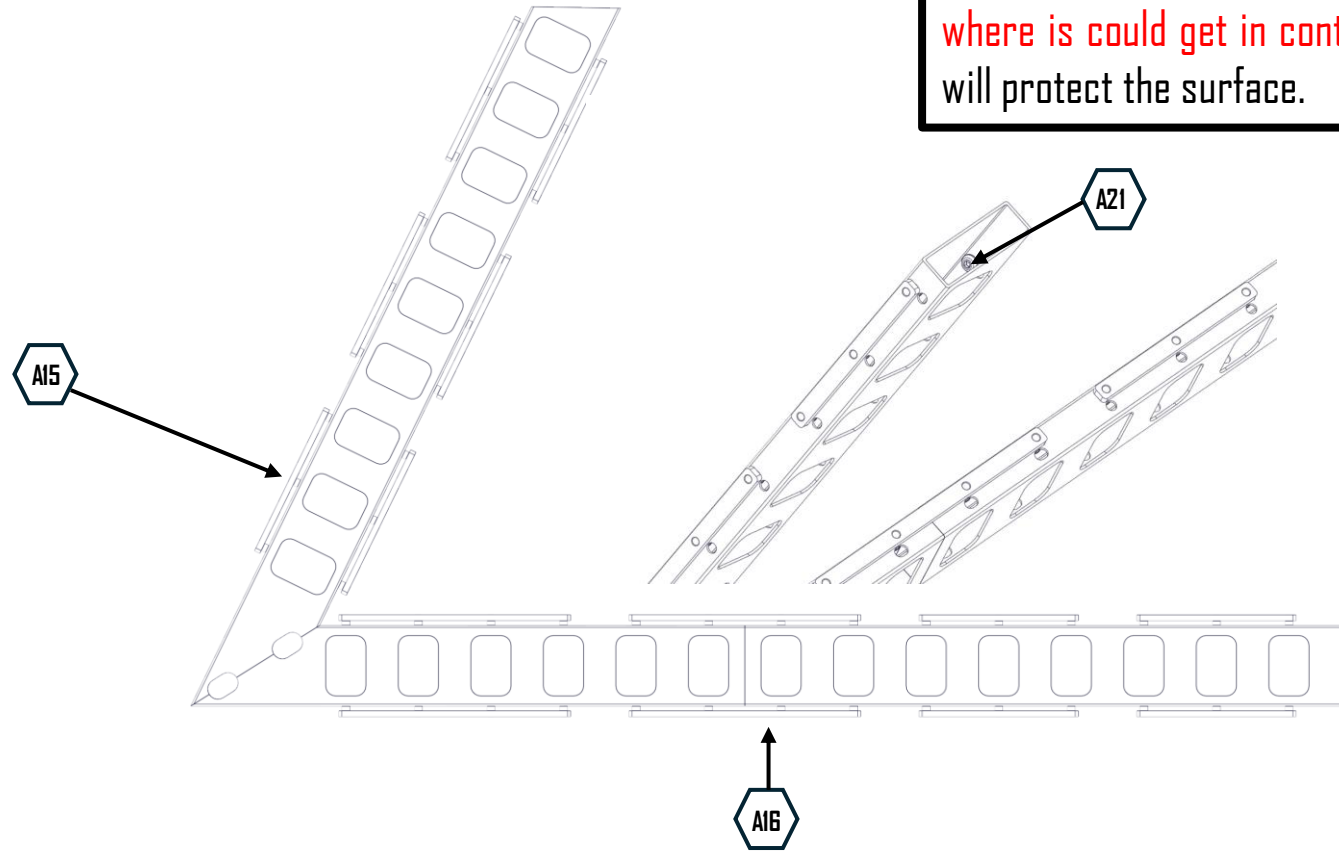

RIGHT Side

BASEFRAME

7 / 43

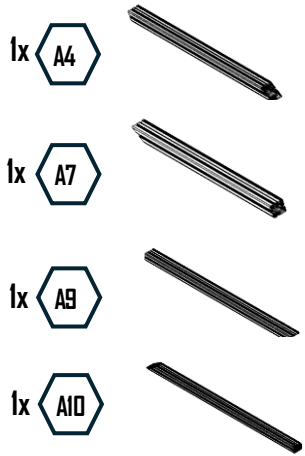

A4 = 817mm

A7 = 636mm

A9 = 1022mm

A10 = 1218mm

T-Slot on the left side!

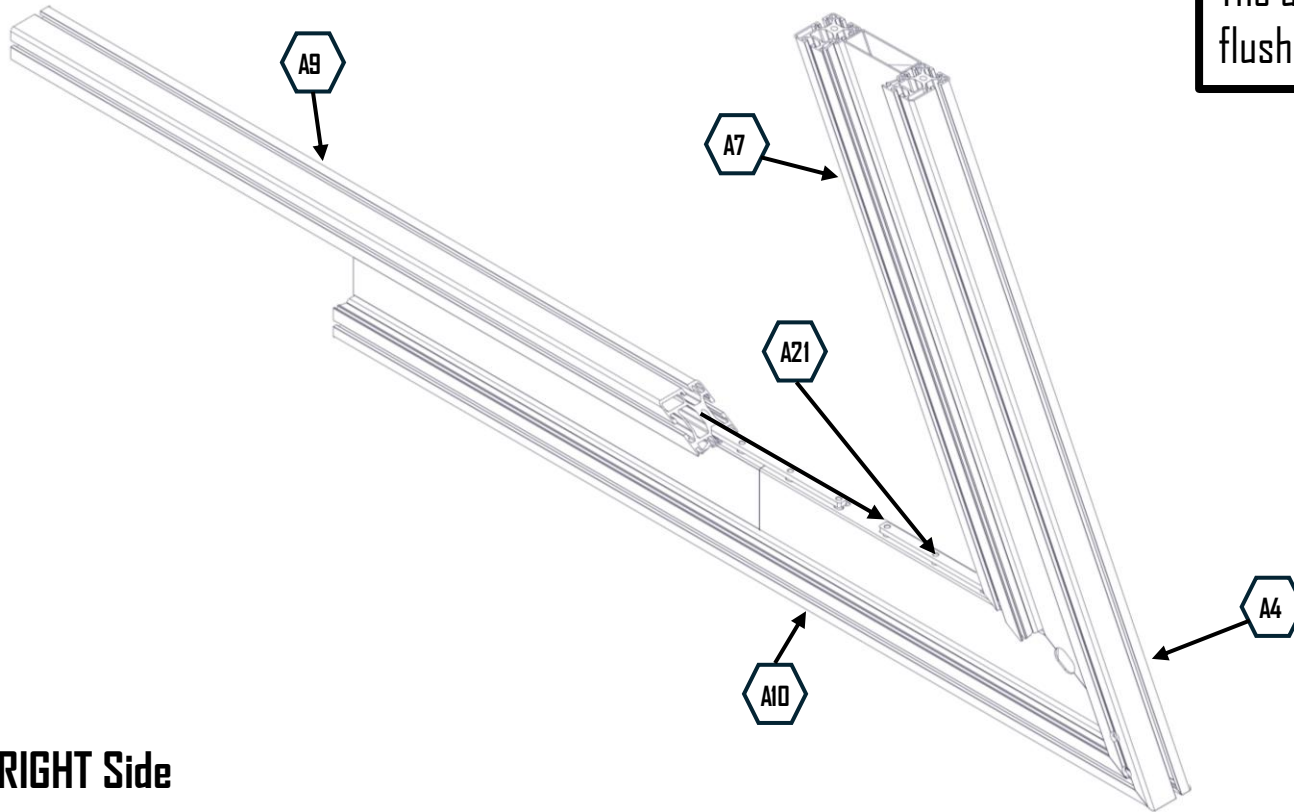

RIGHT Side

Carefully slide all four aluminium extrusions over the prepared T-nuts.

If you encounter any resistance, slightly loosen the nearest (A21) screw.

Then, tighten all 48 (A21) screws.

The aluminium extrusions and base frame parts should fit flush at the rear and top.

BASEFRAME

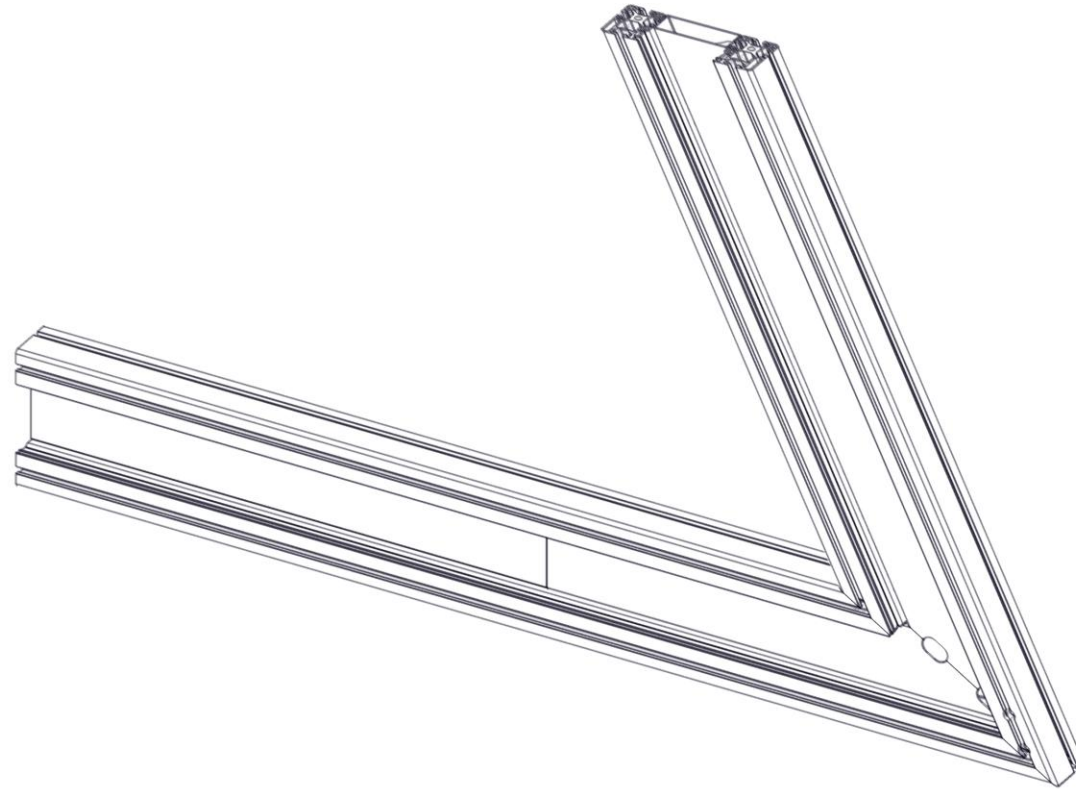

You have finished the right-hand frame.
Now let's follow the same steps for the left frame



RIGHT Side

BASEFRAME



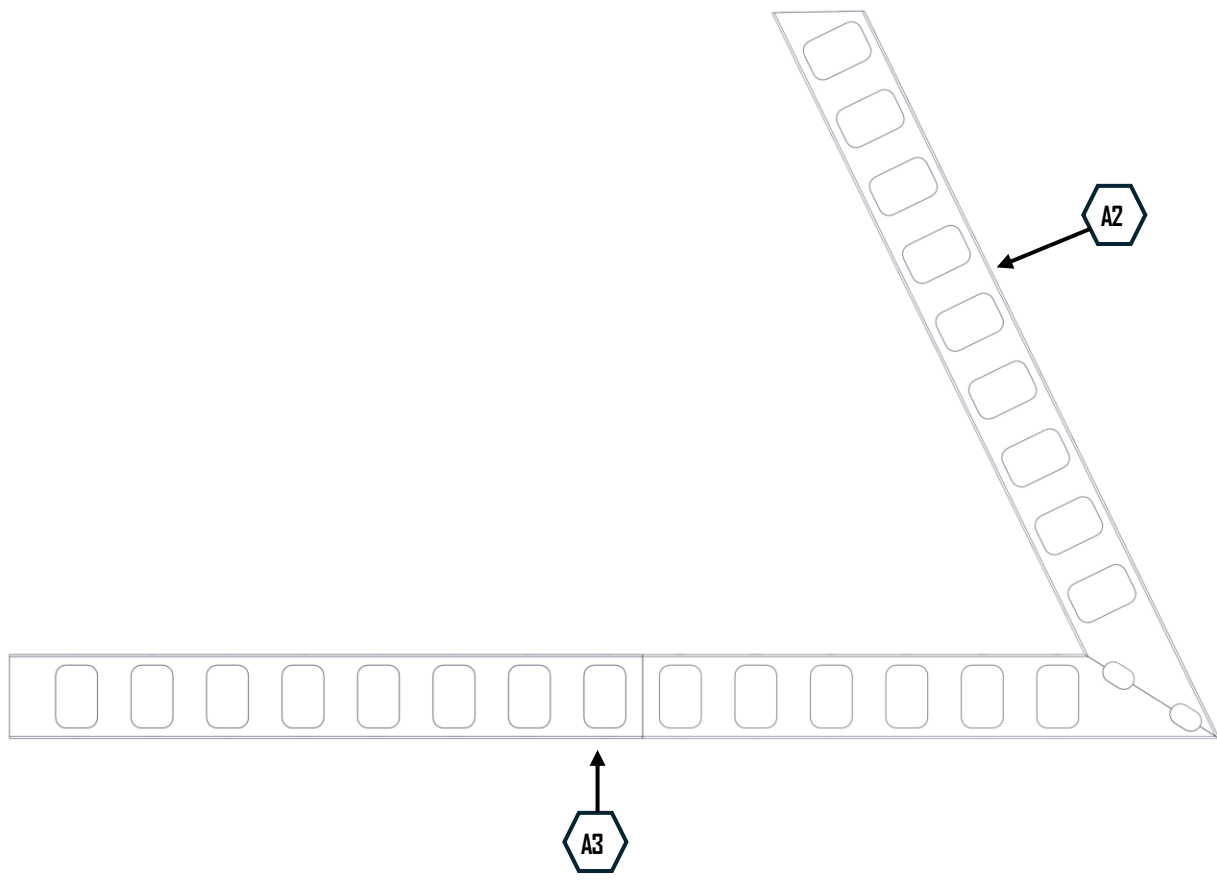

Arrange the (A2) base angle and the (A3) base profile on a flat, protected surface.

- 1x A3 
- 1x A2 

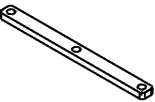

LEFT Side

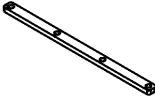
BASEFRAME

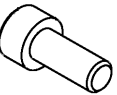
- 10x  
- 4x  
- 46x  

Only fasten the (A21) M8x12 screws by one turn so that the T-nut can slide into the aluminium profiles.

Use the outer holes in (A1) and (A3).

LEFT Side

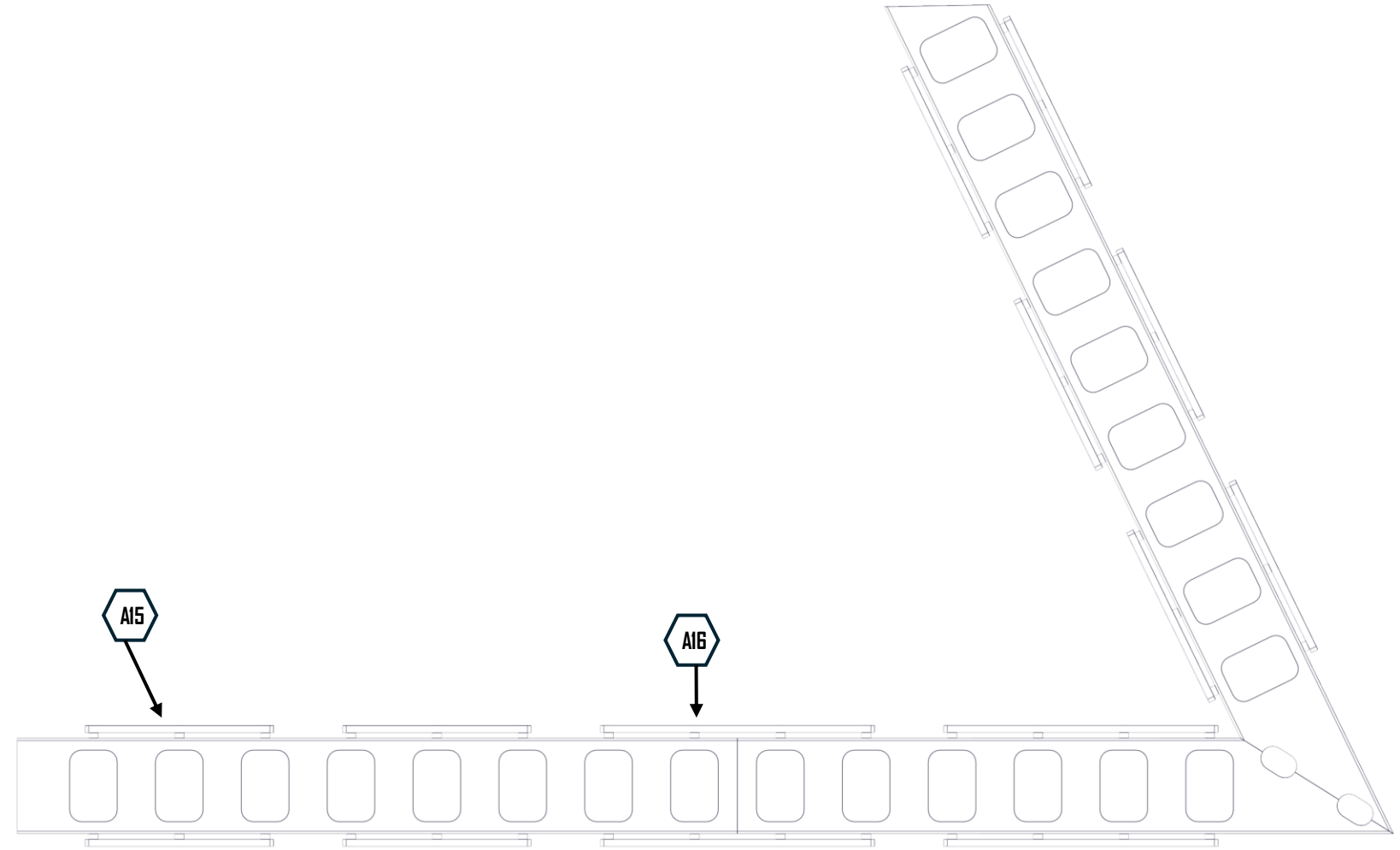

BASEFRAME

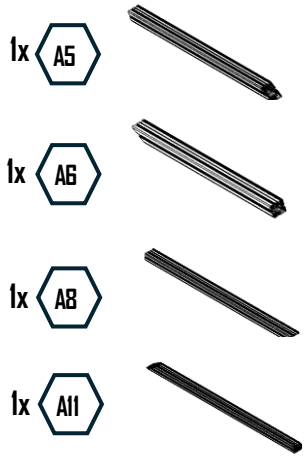

A5 = 817mm

A6 = 636mm

A8 = 1022mm

A11 = 1218mm

T-Slot on the right side!

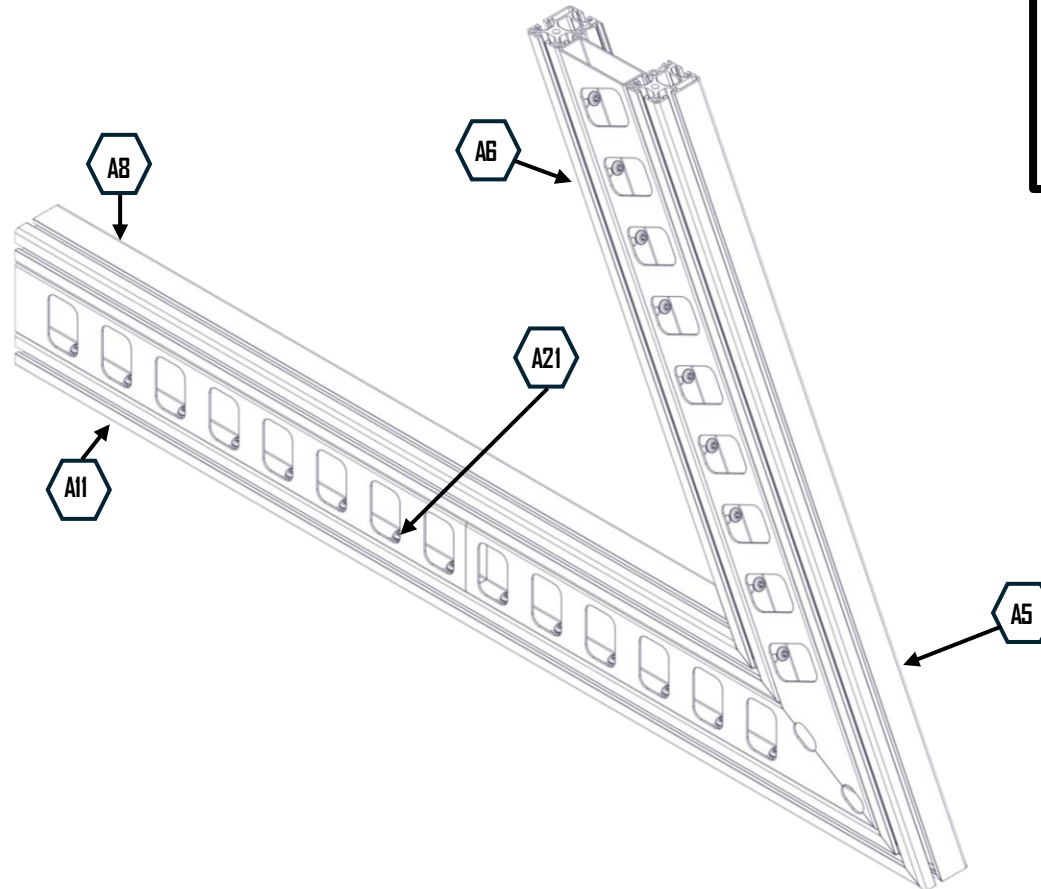

LEFT Side

BASEFRAME

Carefully slide all four aluminium extrusions over the prepared T-nuts.

If you encounter any resistance, slightly loosen the nearest (A21) screw. Then, tighten all 48 (A21) screws.

The aluminium extrusions and base frame parts should fit flush at the rear and top.

You have finished the left frame.

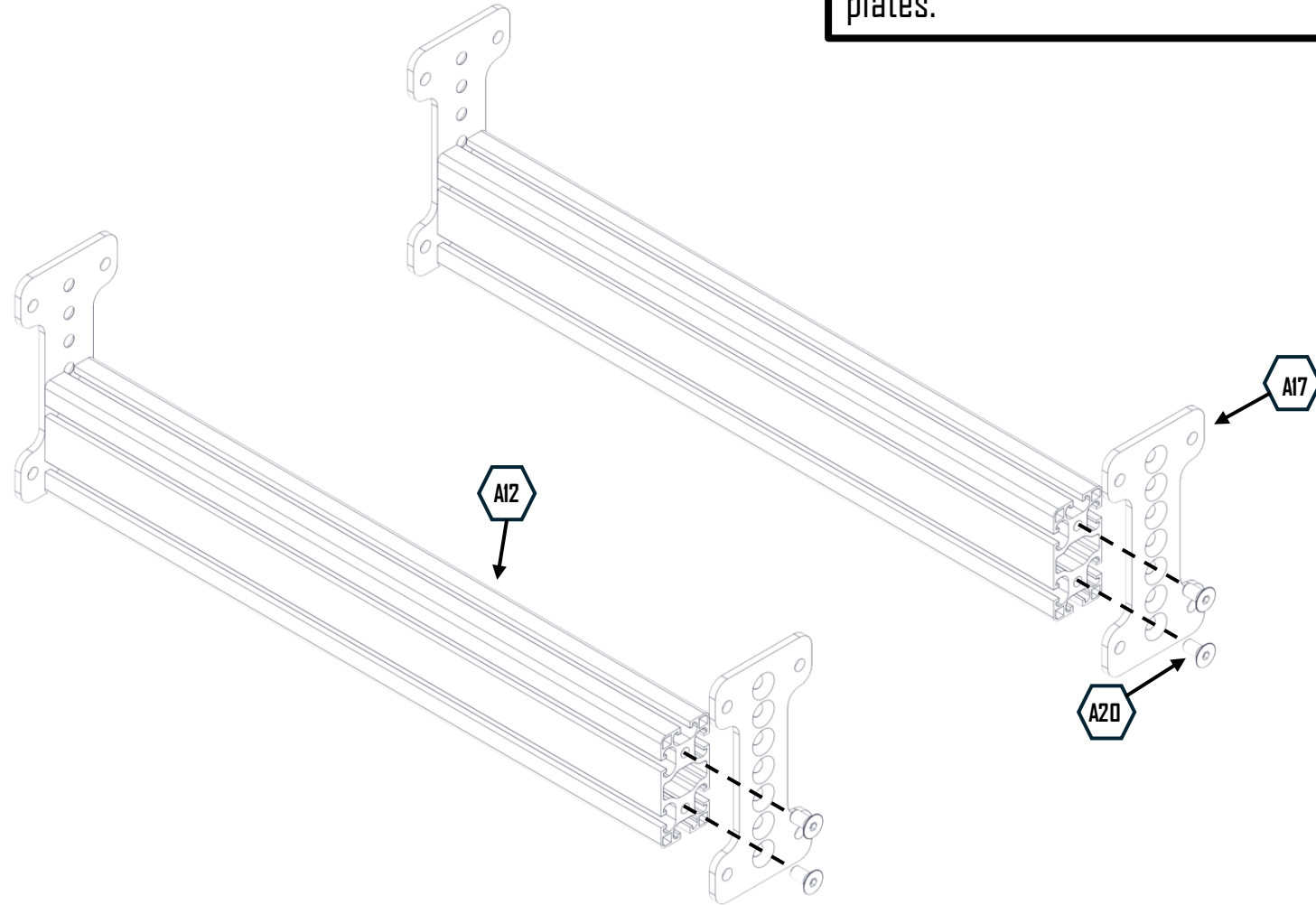
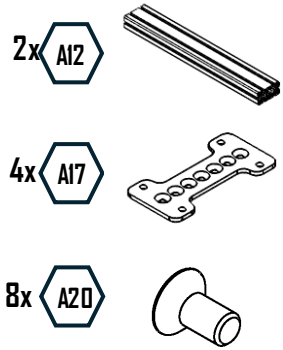

Connect all four plates to the ends of the aluminium extrusions using the (A20) M8x16 countersunk screws.

You can vary the seating height by choosing a different mounting position. This must be the same for all four plates.

4x A18

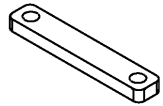

16x A19

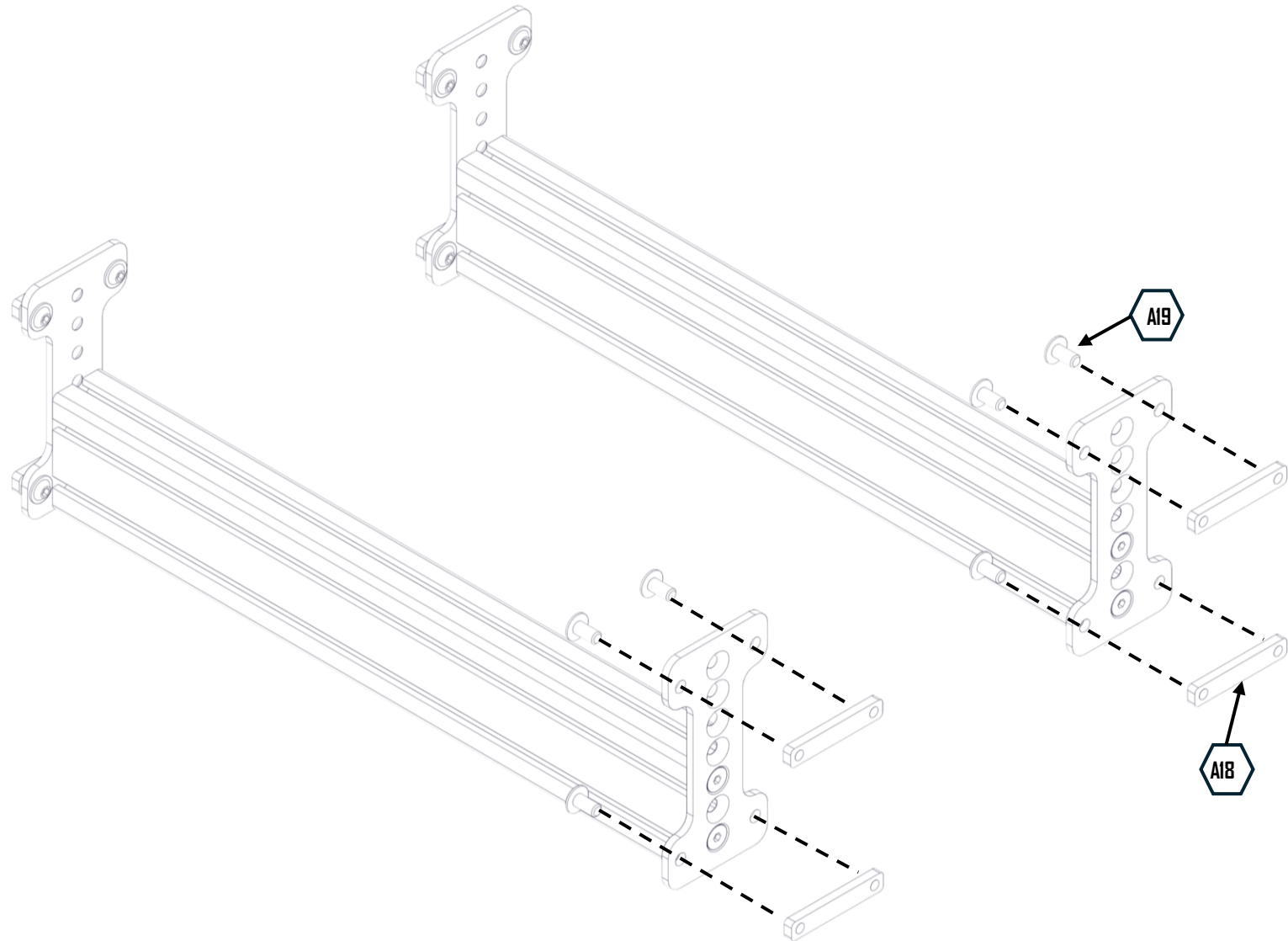

As with the frame parts, only tighten the die screws by one turn so that the complete unit can slide easily into the frame in step 10.

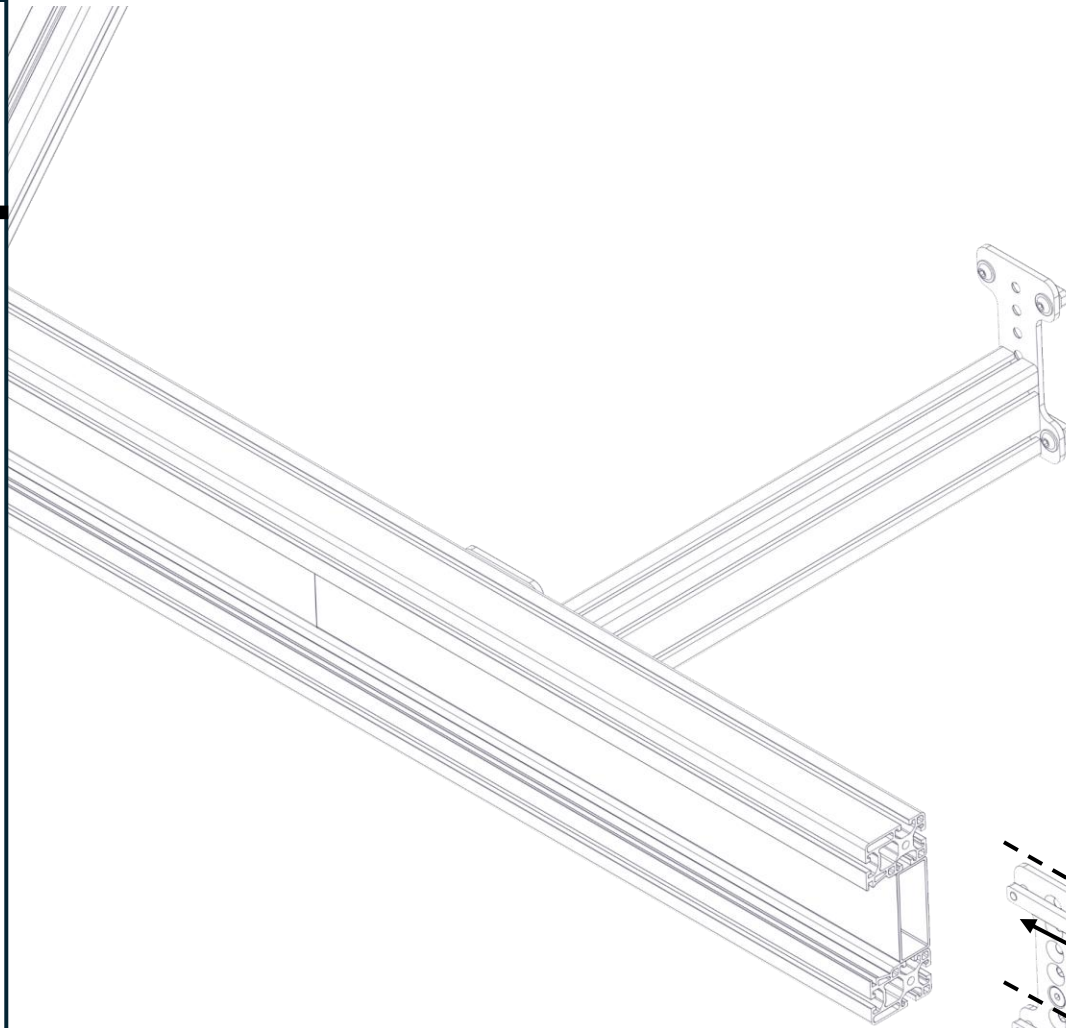

Slide the seatposts in. Choose the position depending on your size. If you are taller, position the rear seat post around 5 cm from the end of the frame.

The front seat post should then be positioned 325 mm (centre to centre) away from the rear seat post. Finally, fasten all the screws.

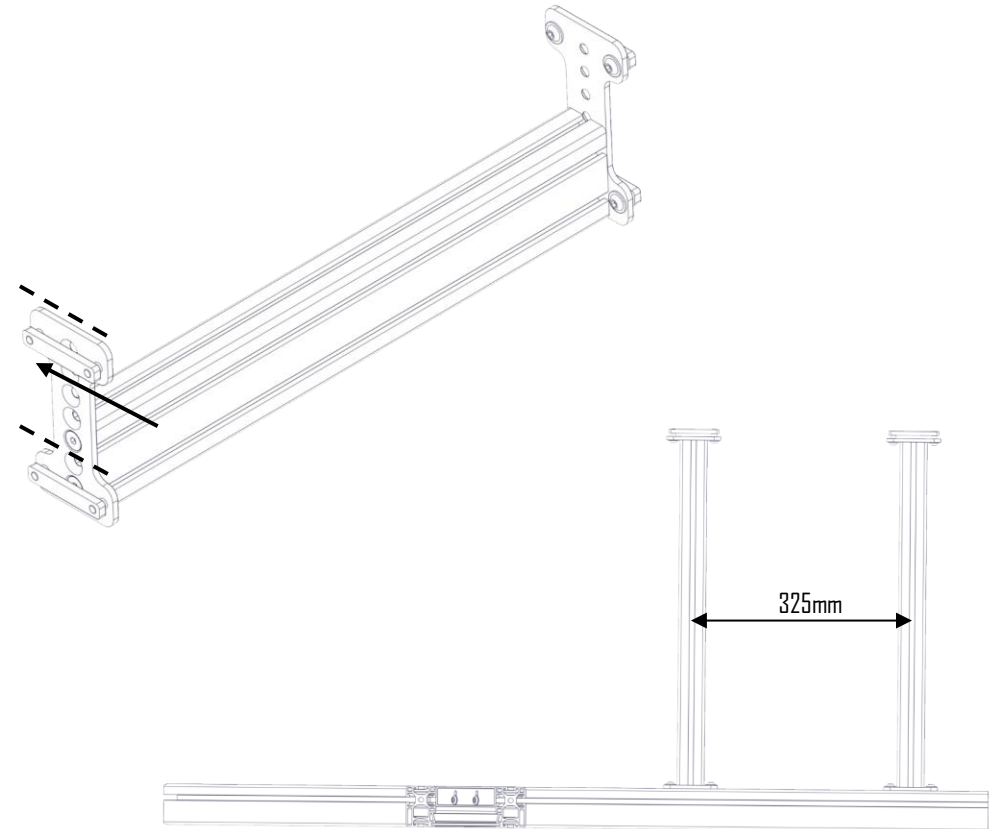

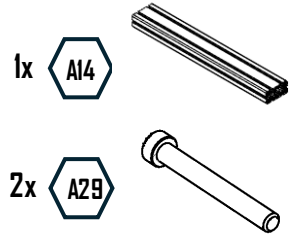

Connect the (A14) support bar with the (A29) M8x65 cylinder screws.

Do not tighten them now.

We will tighten them once the pedal unit has been mounted

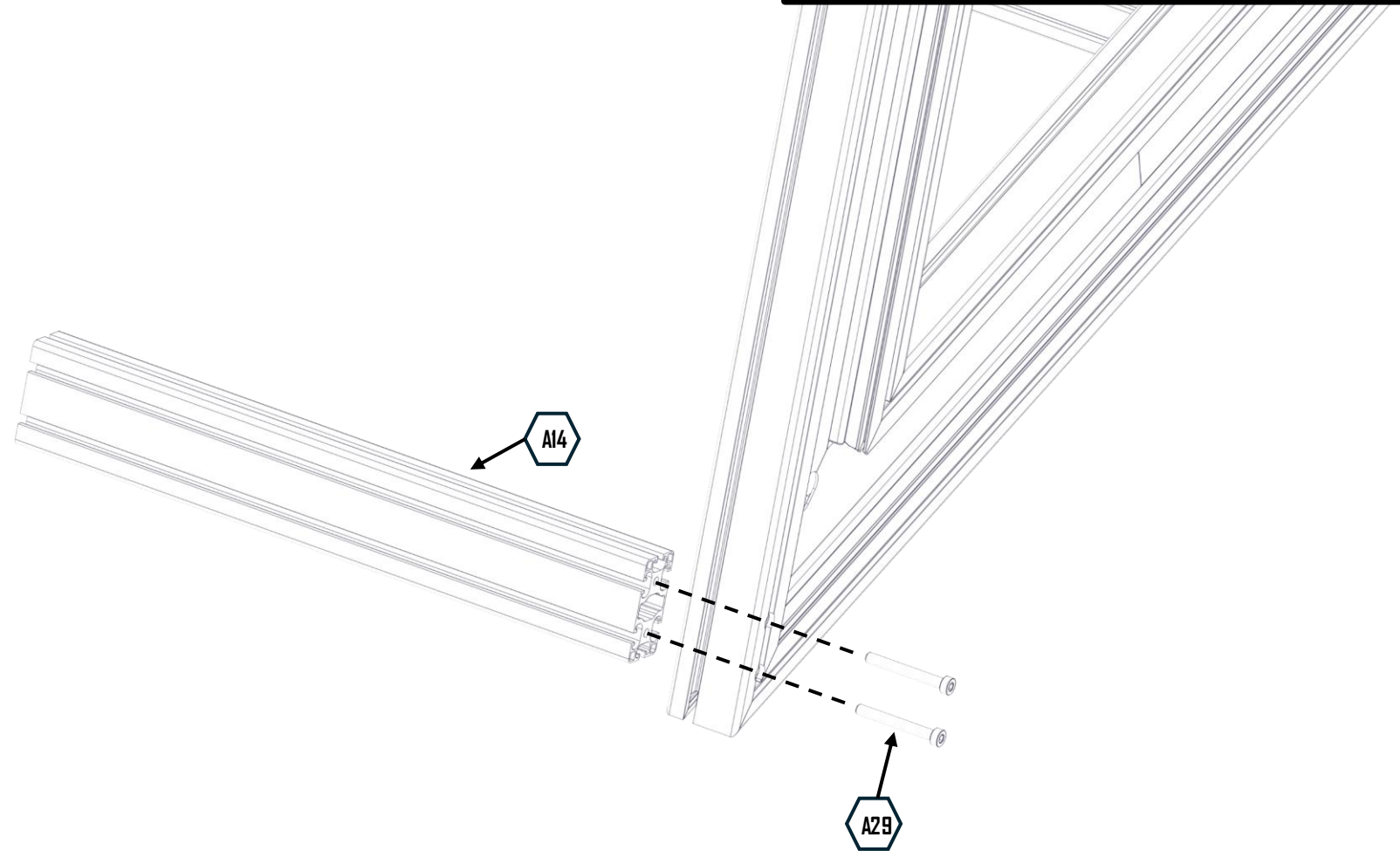

With the help of your working buddy, carefully slide the right frame part onto the other frame part.

As before, take your time and remove any blockages by slightly loosening the jammed T-nut

The frame side parts should be flush at the front and rear. Then tighten all the screws.

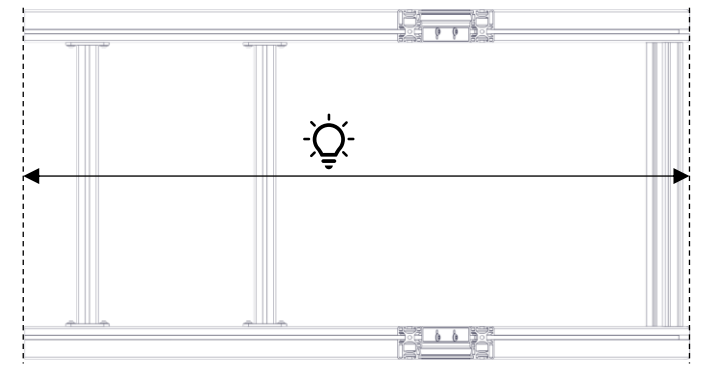
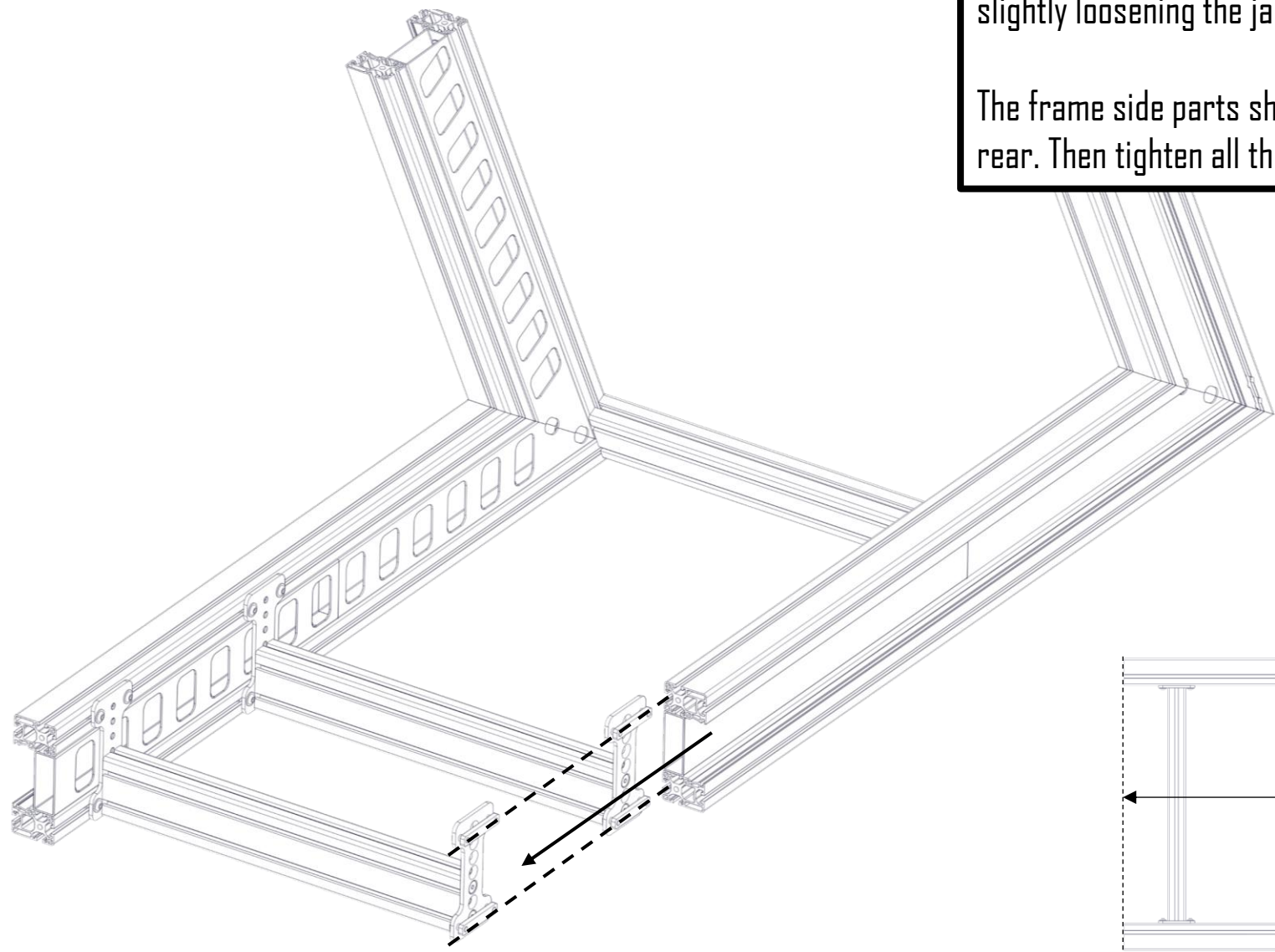

17 / 43

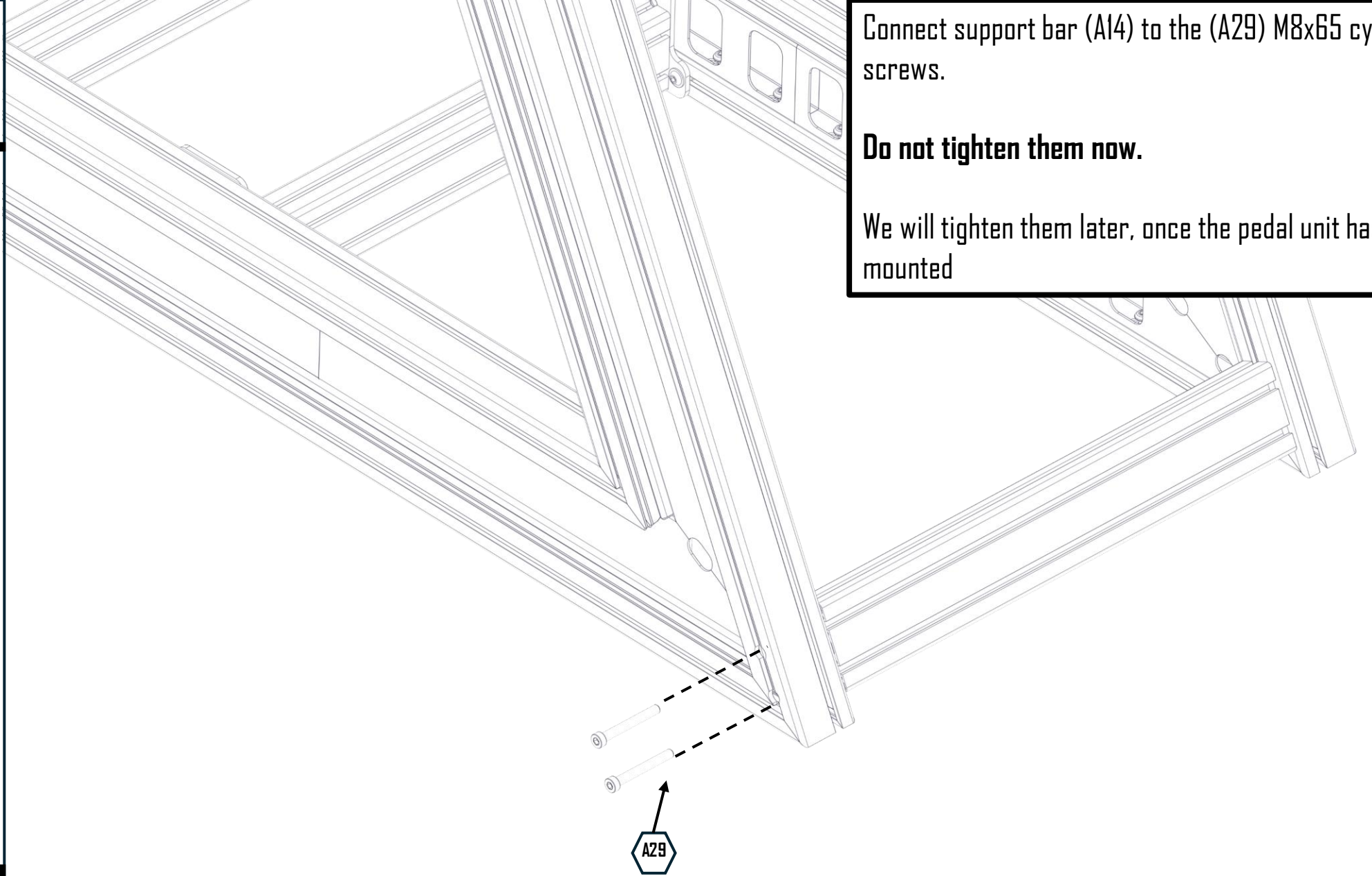

Connect support bar (A14) to the (A29) M8x65 cylinder screws.

Do not tighten them now.

We will tighten them later, once the pedal unit has been mounted

BASEFRAME

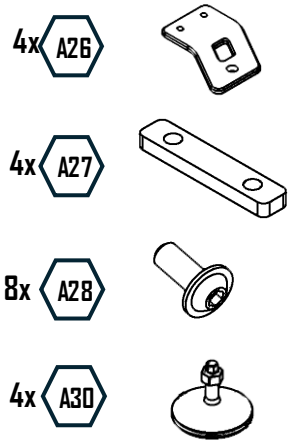

Attach the four feet to the foot plates using A28 M8x20 screws and T-nuts. Insert screws only one turn so they can slide into the frame.

Remove the nut, guide the foot through the foot plate, then secure it again with the nut. Do this for all four feet.

Finally, slide all four units into the frame from the back and tighten the eight screws.

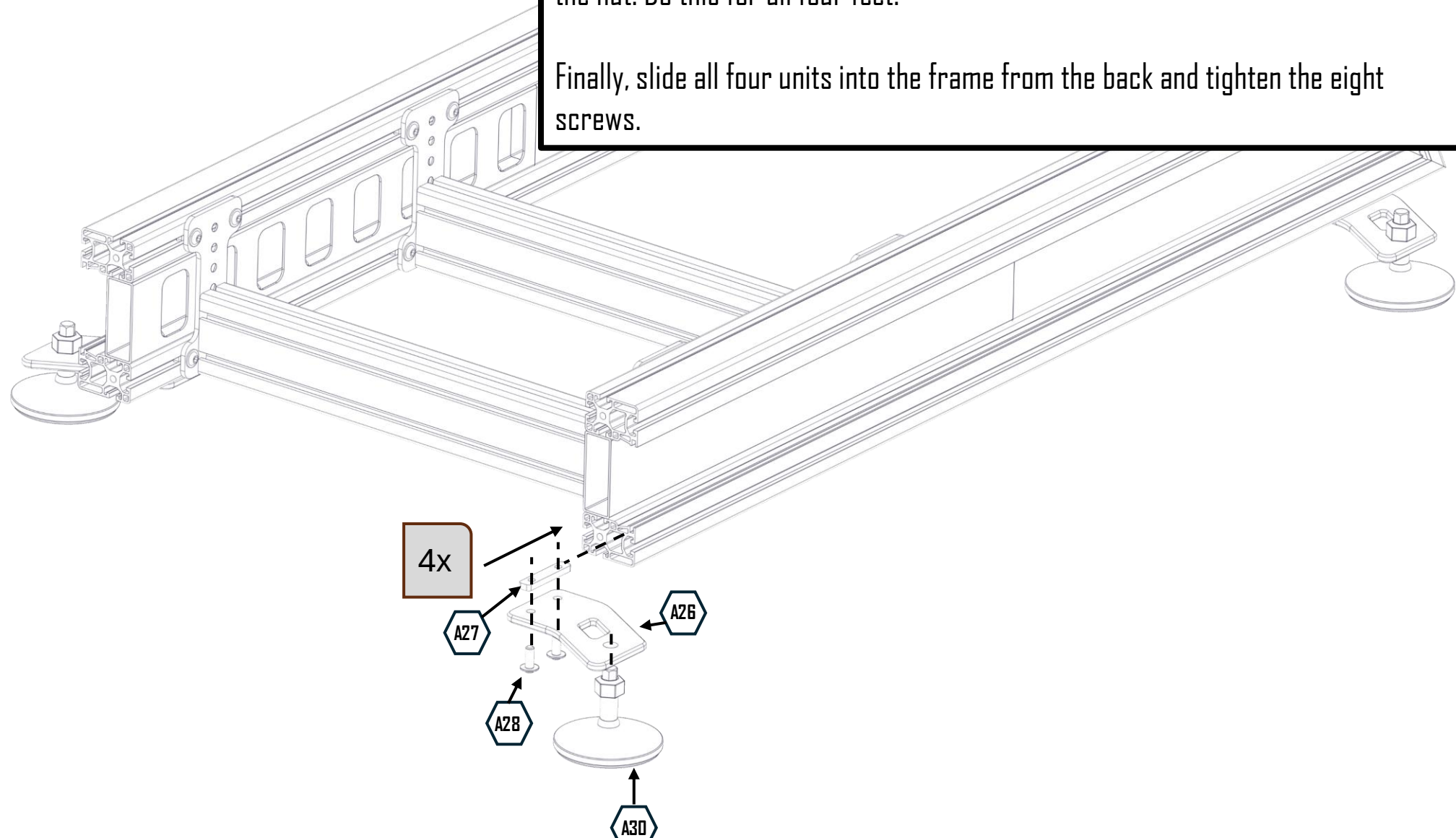

1x L1

1x L2

1x L3

1x L4

Slide all four covers (transparent or featuring a design) into the aluminium extrusions.

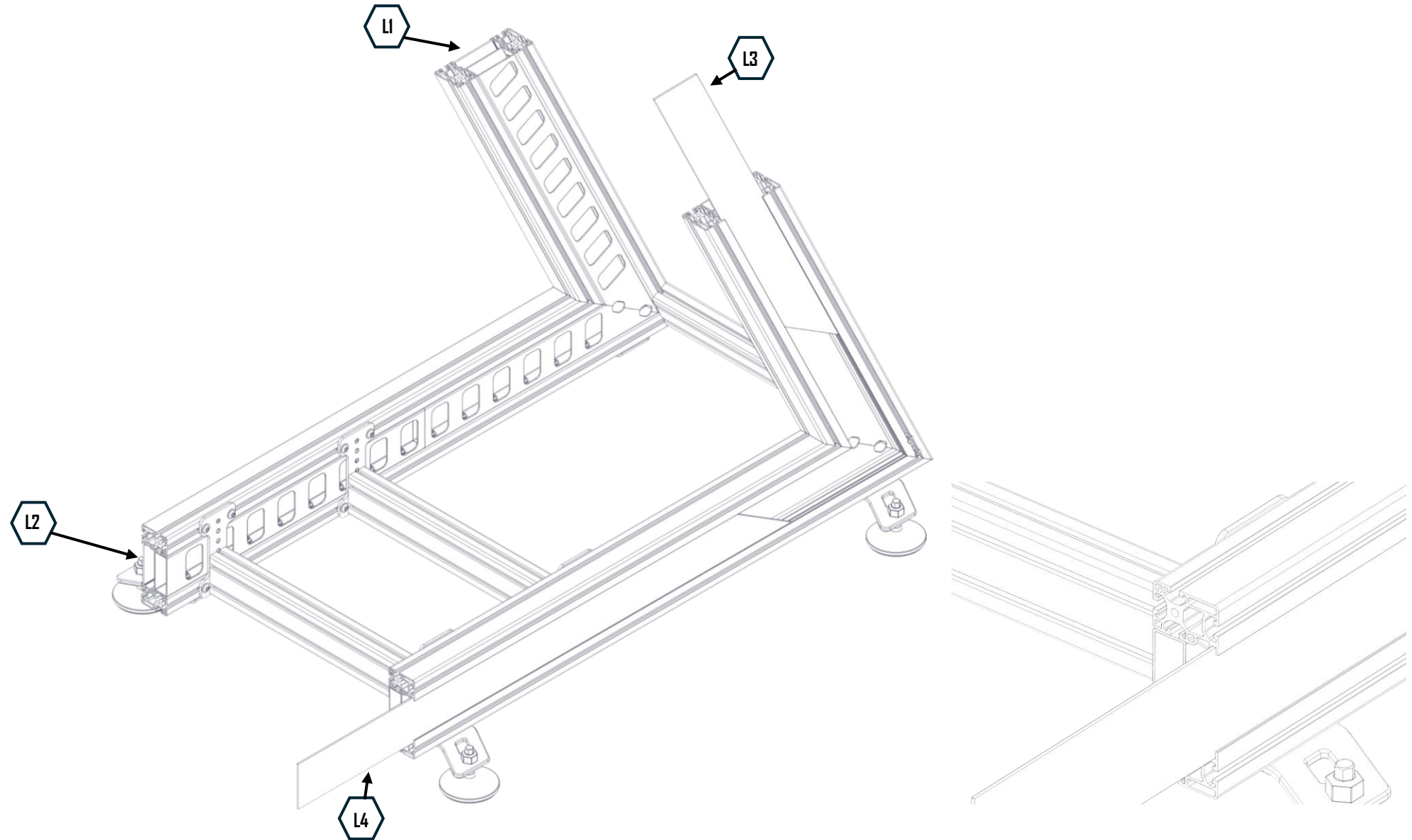

1x A22

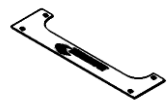

4x A23

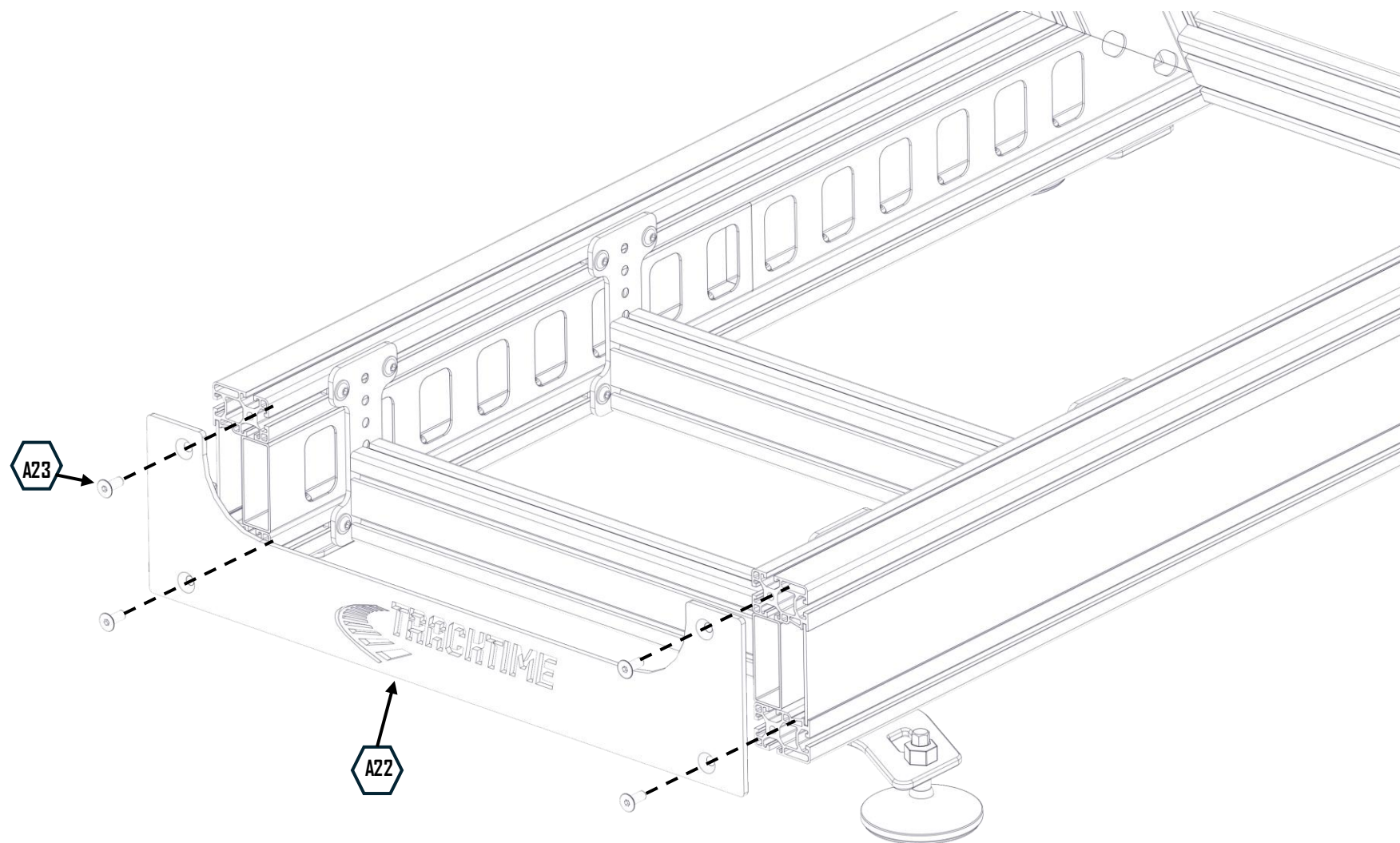









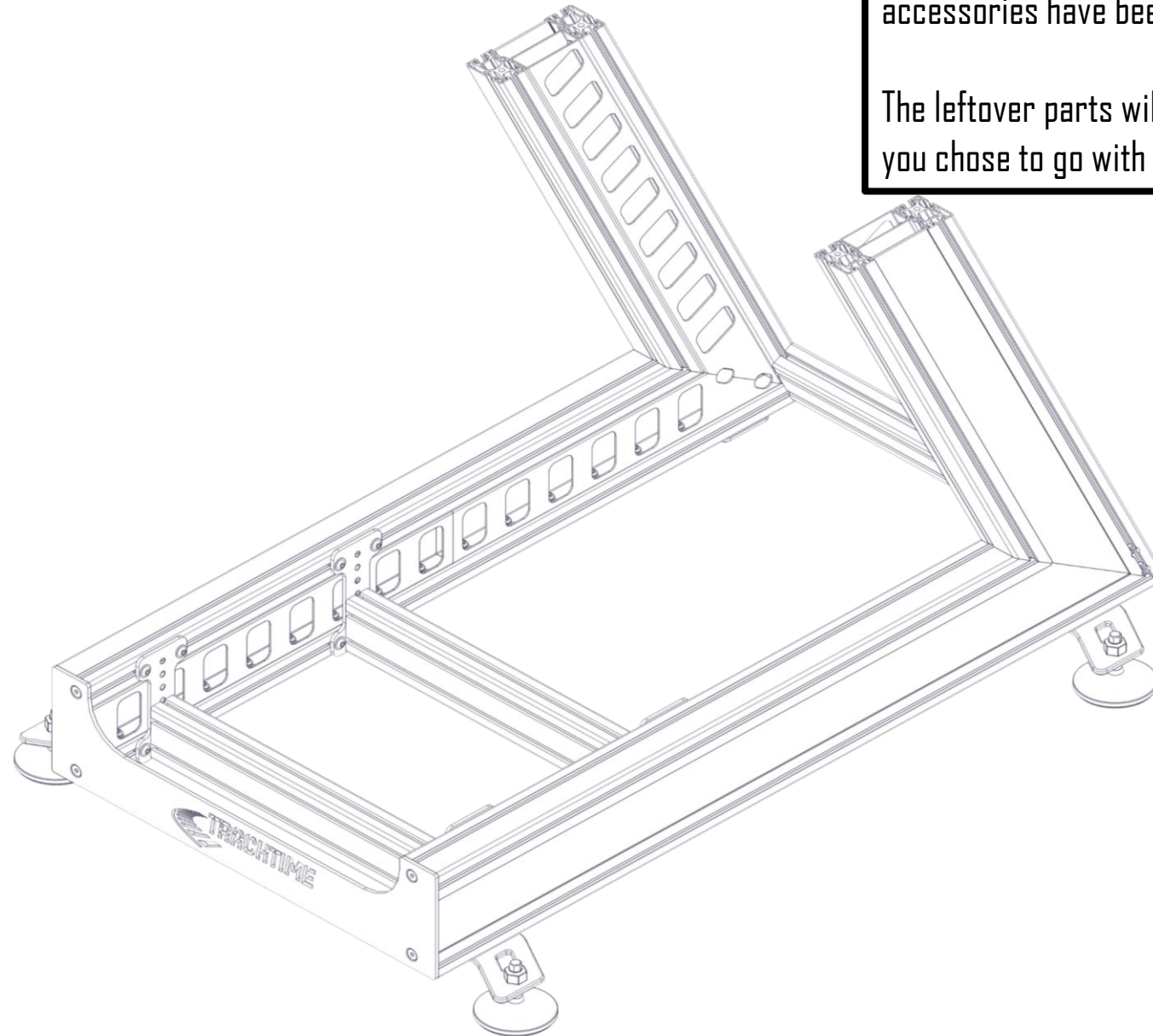

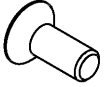

Mount the rear plate using the four (A23) M8x20 countersunk screws.

You have finished your new base frame.

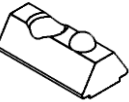
We will install the upper end caps later, once all the accessories have been installed.

The leftover parts will be used for the wheel holder that you chose to go with your rig.

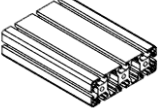

- 4x  
- 8x  
- 8x  
- 1x  
- 1x  
- 2x  



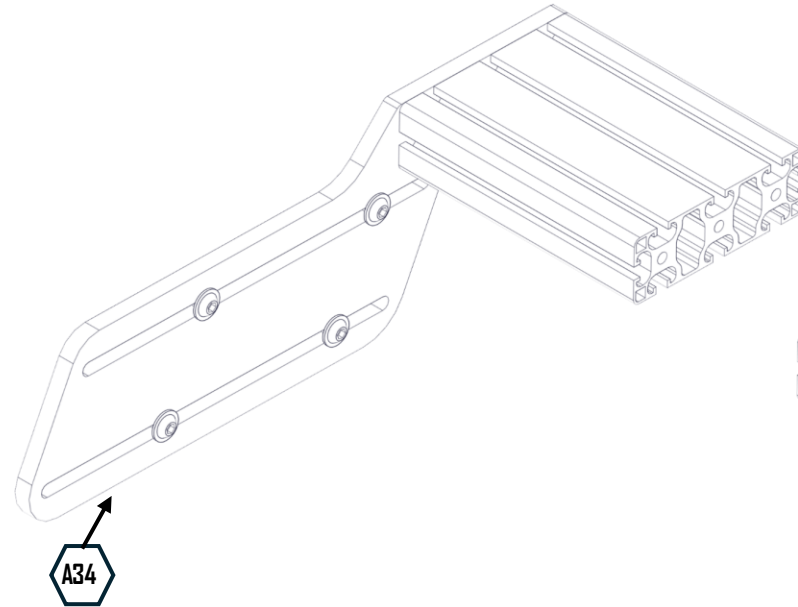

WHEEL UNIT (BASEFRAME PARTS)

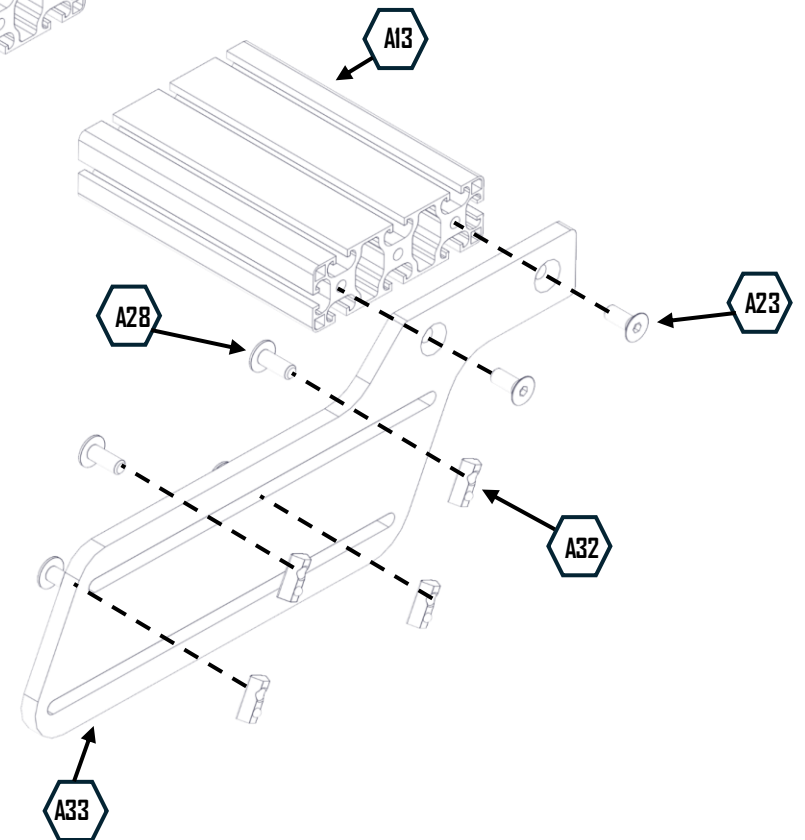

First, connect the left and right wheel brackets to the 120 x 40 aluminium extrusions. Use the (A23) M8x20 countersunk screws.



Then connect the eight locknuts to the wheel brackets using the M8x20 lens screws. Fasten them by one turn only so that we can slide this unit into the base frame later.

- 1x H1 
- 1x H4 
- 1x H6 
- 8x H8 

WHEEL UNIT (FRONTMOUNT SOLUTION)

Connect the front faceplate to the left and right wheel brackets.
Use the (H8) M8-20 screws. For now, adjust the wheelplate to an upright position.

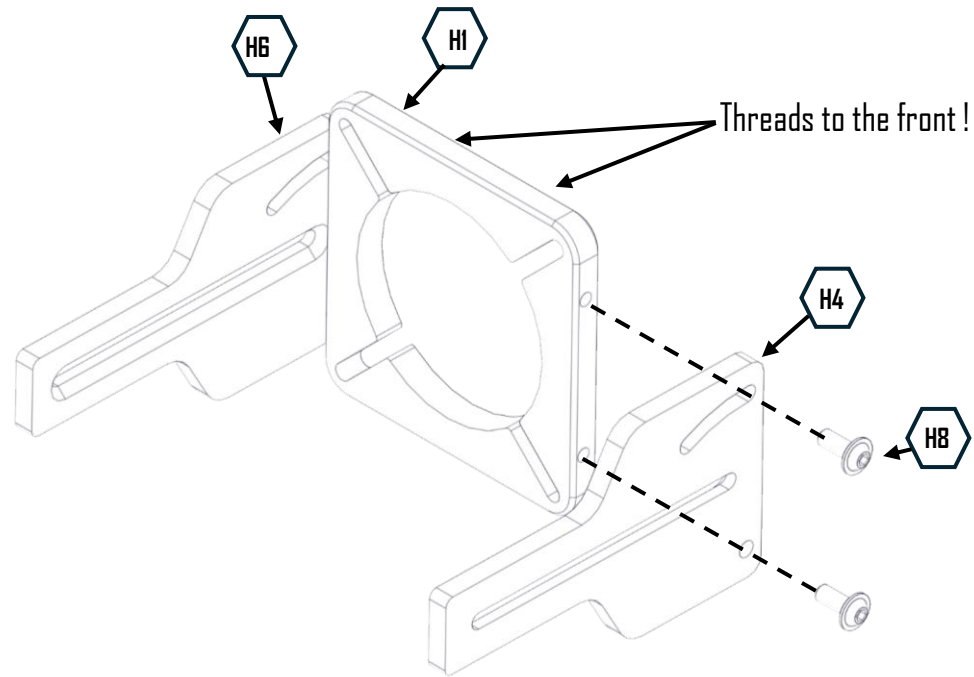



Connect the pre-mounted base frame wheel units (left and right) to the newly mounted front mount wheel unit using four (H7) M8x20 lens screws.

For now, adjust both sides to the frontmost position to make mounting to the baseframe easier.

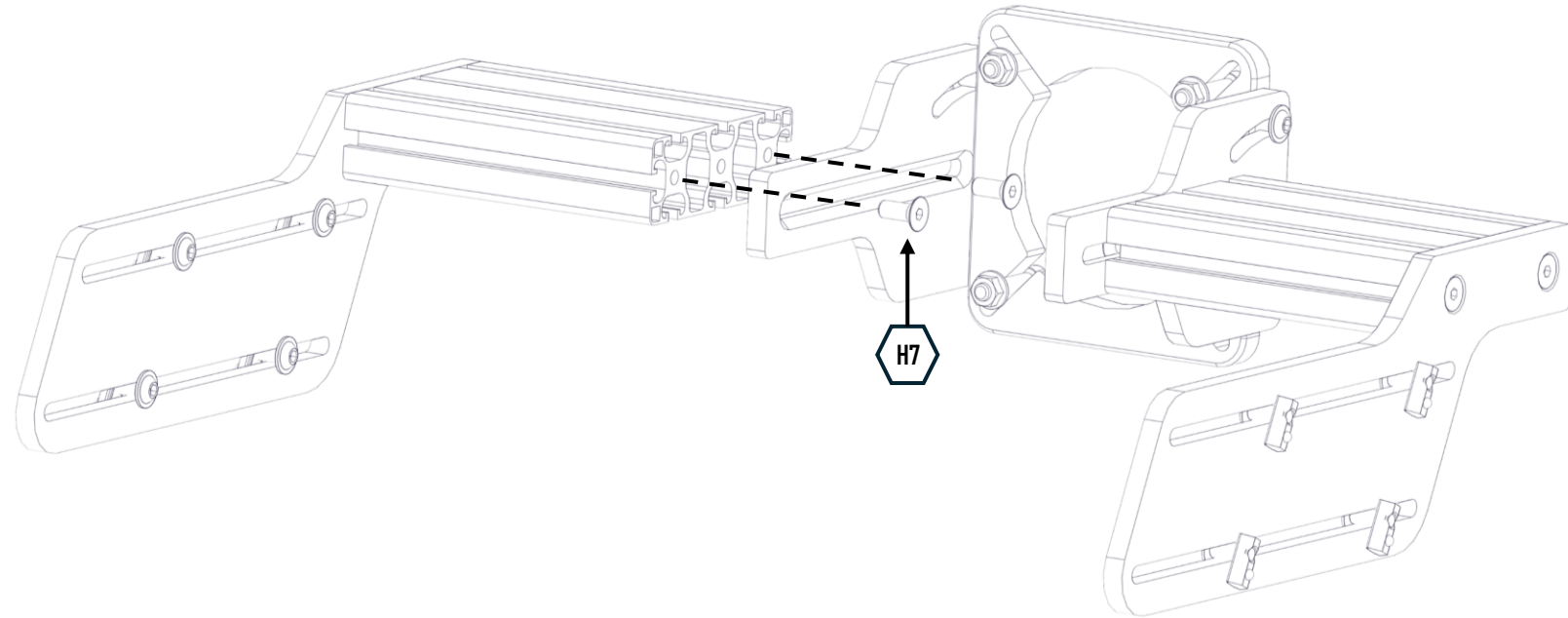

**WHEEL UNIT
(FRONTMOUNT
SOLUTION)**

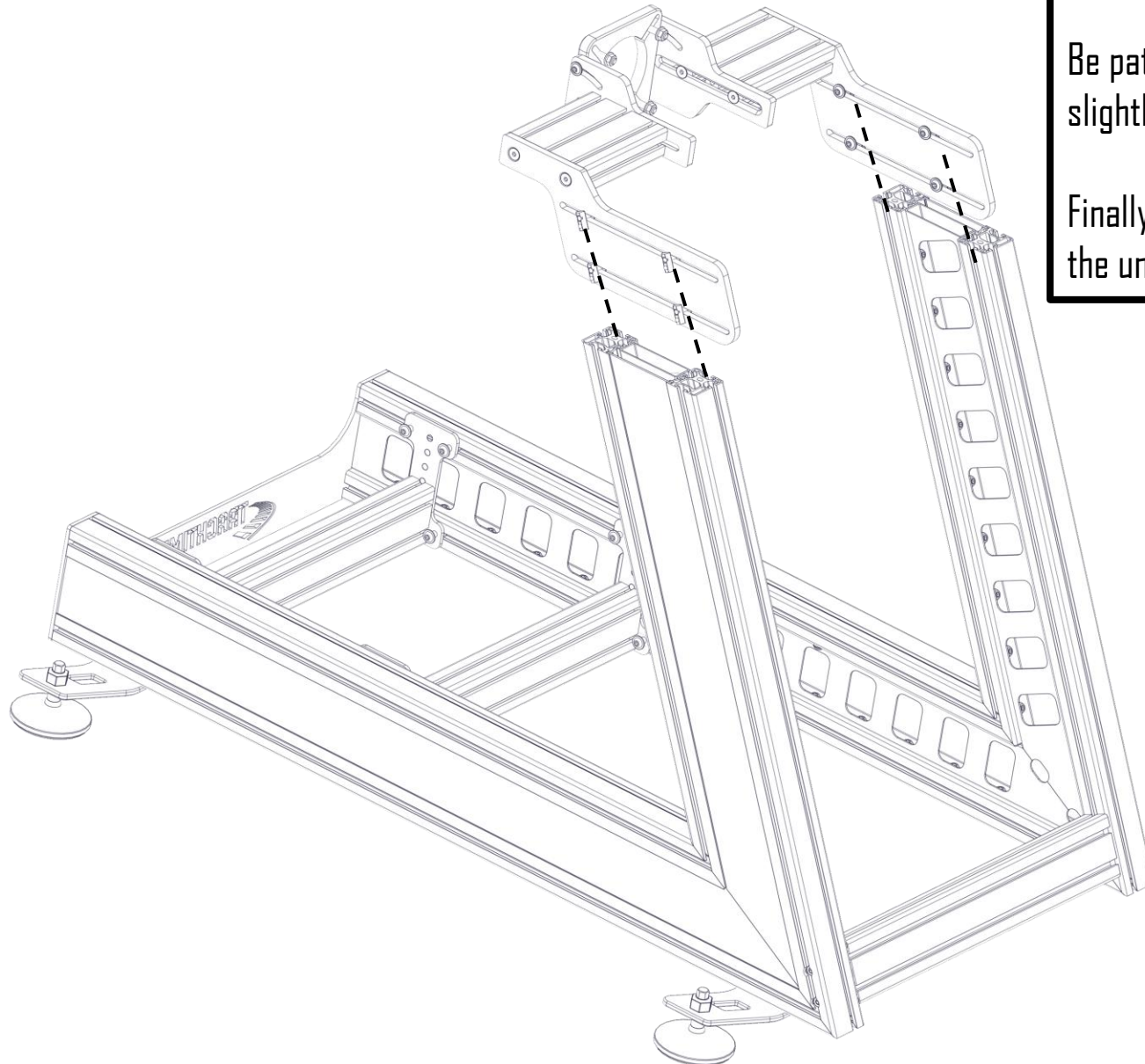

It is better to do this with another person. Mount the wheel unit to the base frame by sliding the T-nuts into the frame.

Be patient and take care. As before, if a T-nut gets stuck, slightly loosen the screw.

Finally, fasten all eight screws once you have positioned the unit in the desired position.

26 / 43

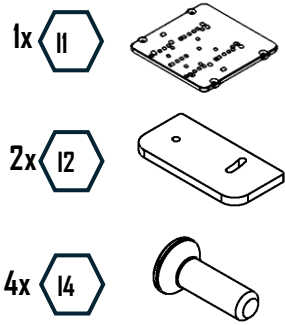

Connect the wheel plate and both wheel brackets. Use four of the (H14) M6x20 countersunk screws.

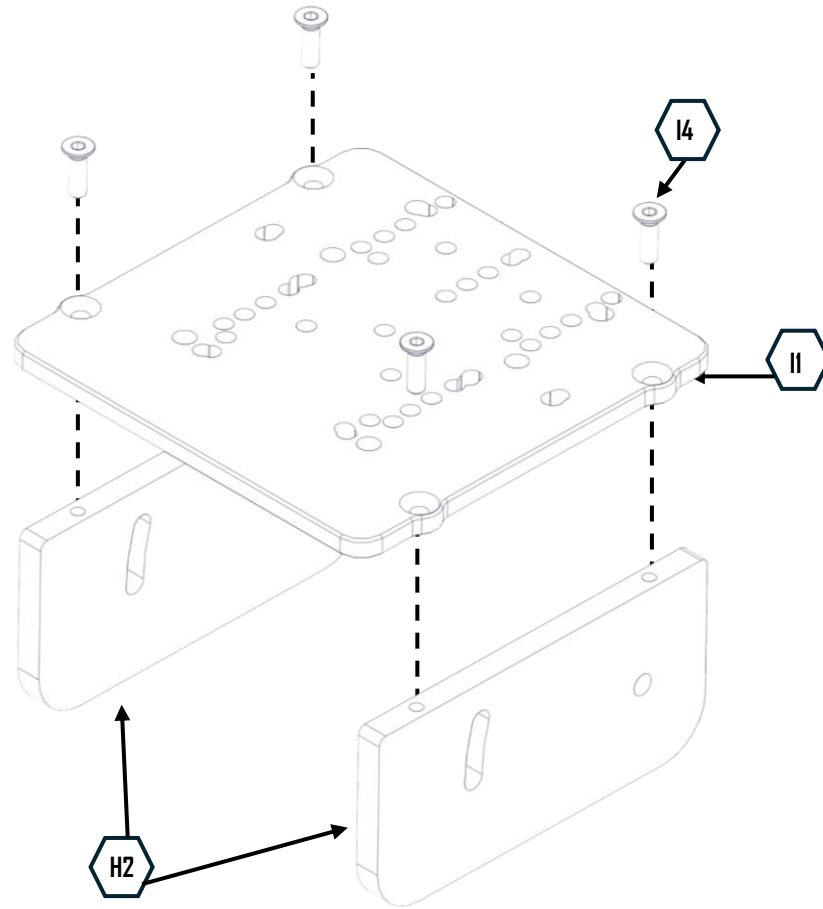

**WHEEL UNIT
(TOPMOUNT SOLUTION)**

27 / 43



Connect the pre-mounted base frame wheel units (left and right) to the newly mounted top mount wheel unit using four (13) M8x20 lens screws.

For now, ensure that both sides are 100% straight to make mounting to the baseframe easier.

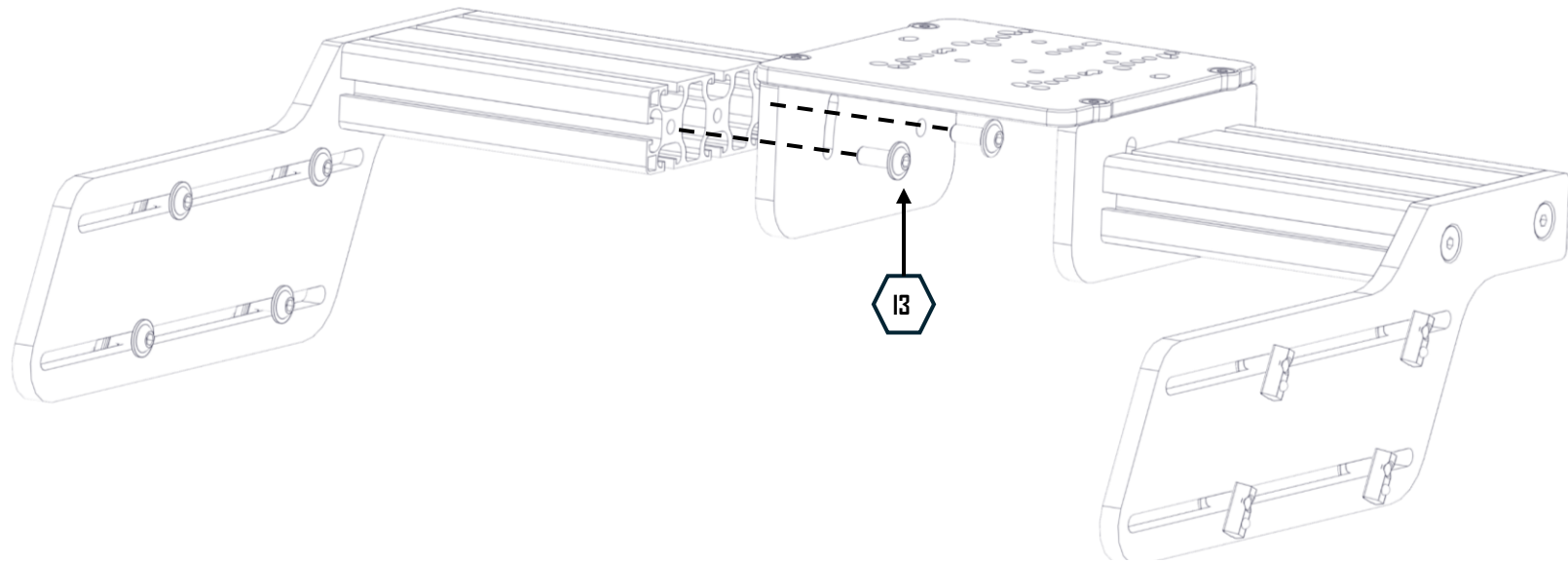

**WHEEL UNIT
(TOPMOUNT SOLUTION)**

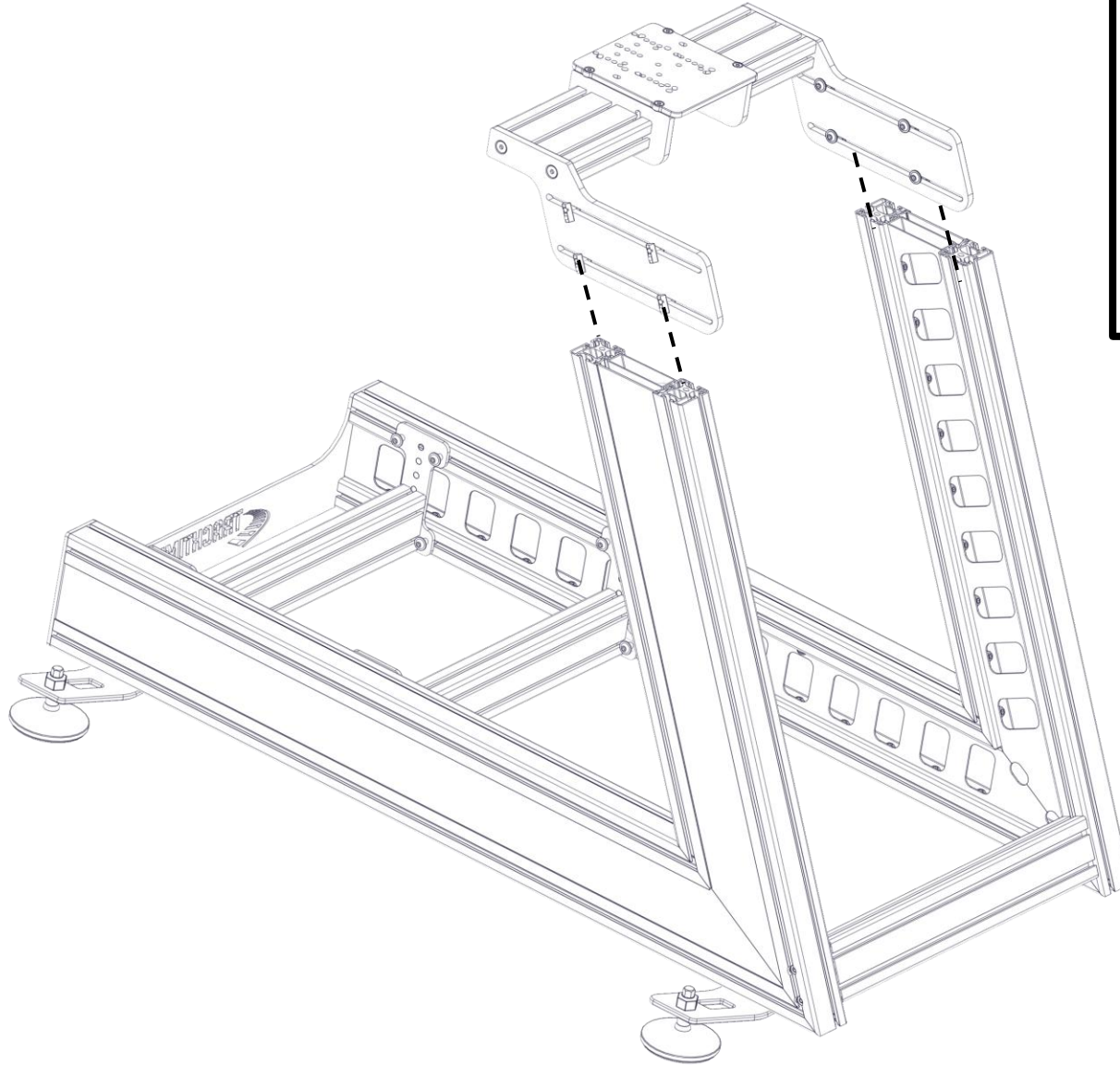

It is better to do this with another person. Mount the wheel unit to the base frame by sliding the T-nuts into the frame.

Be patient and take care. As before, if a T-nut gets stuck, slightly loosen the screw.

Finally, secure all eight screws once you have positioned the unit in the desired position.

Your Choice:

You can swap D3 and D2 : Then the Front angle of the pedal unit follows the frame

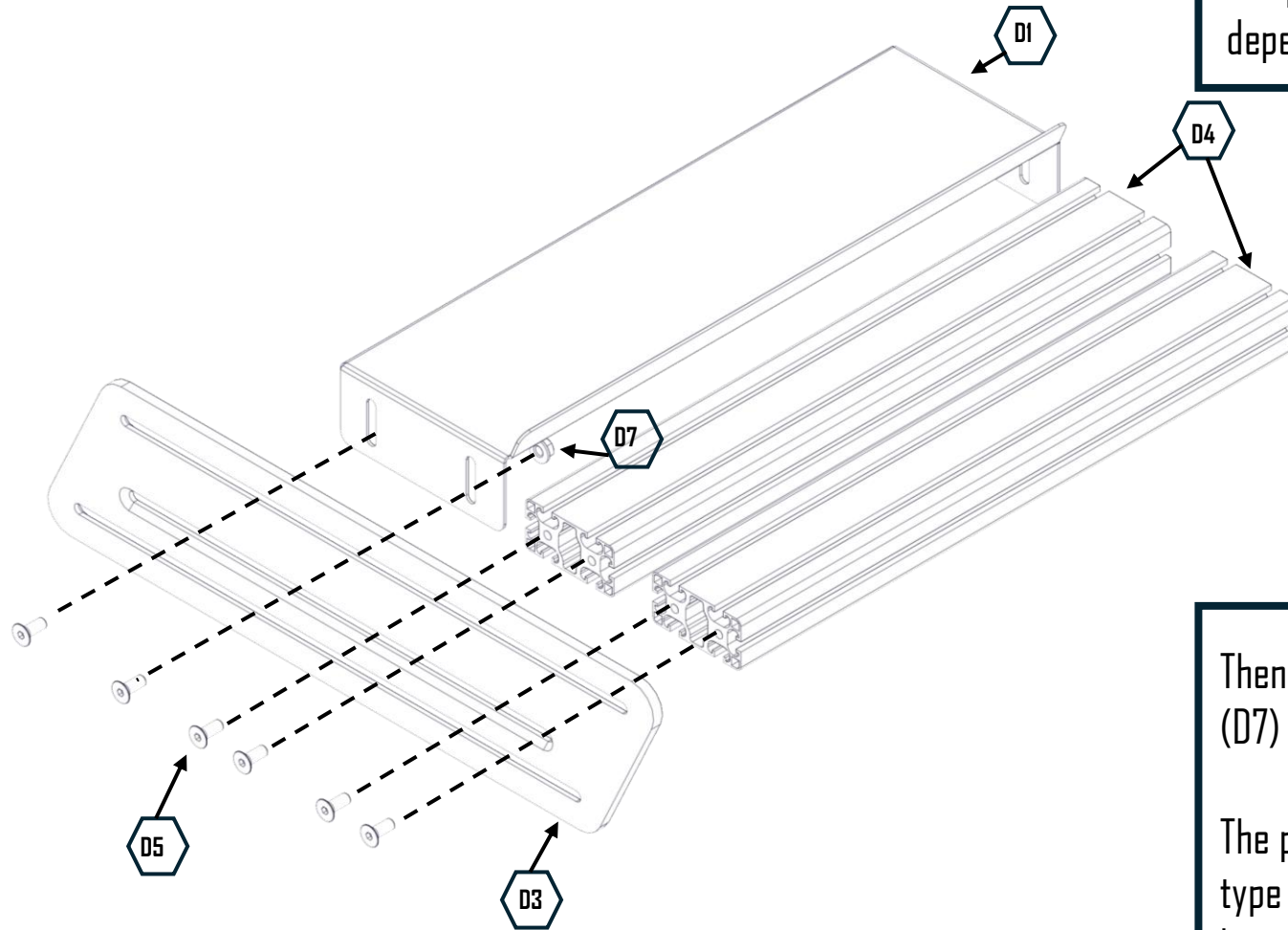
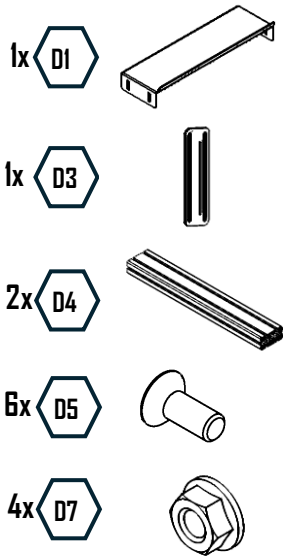

First, take the right pedal bracket (D3), then assemble both aluminium extrusions with four (D5) M8x20 countersunk screws.

The position and distance from each other depend on your choice and the type of pedals.

Then mount the footplate using (D5) screws and (D7) locknuts.

The position depends on your preference and the type of pedals you have. The heel rest should be located in front of your pedals, so find a position that is convenient for you.

30 / 43

Rotate the unit through 180 degrees around the Z-axis.

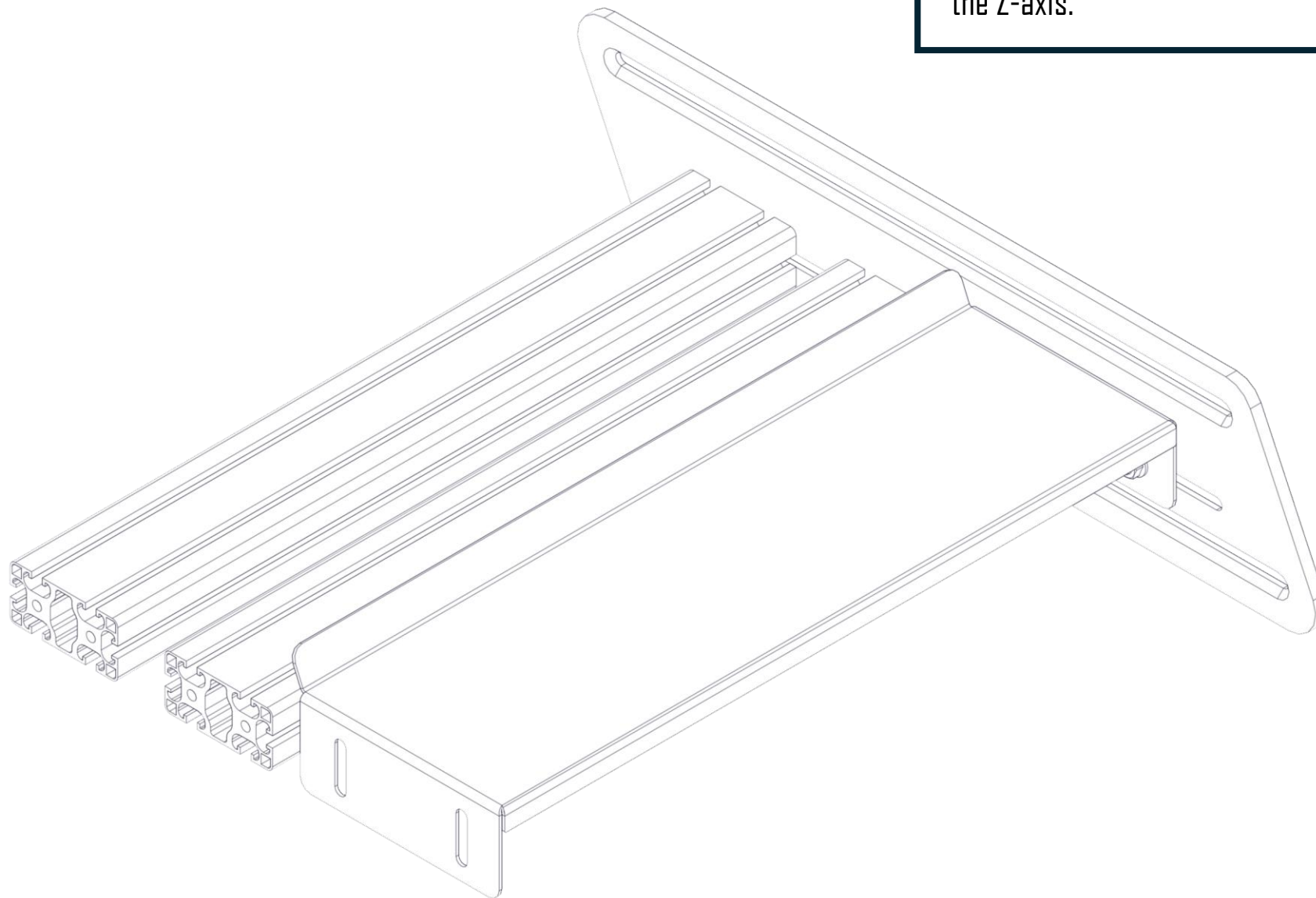

PEDAL UNIT

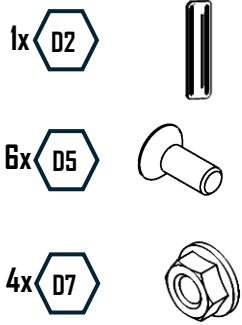

First, take the left pedal bracket (D2) and assemble both aluminium extrusions with four (D5) M8x20 countersunk screws.

Next, secure the footplate using (D5) screws and (D7) lock nuts.

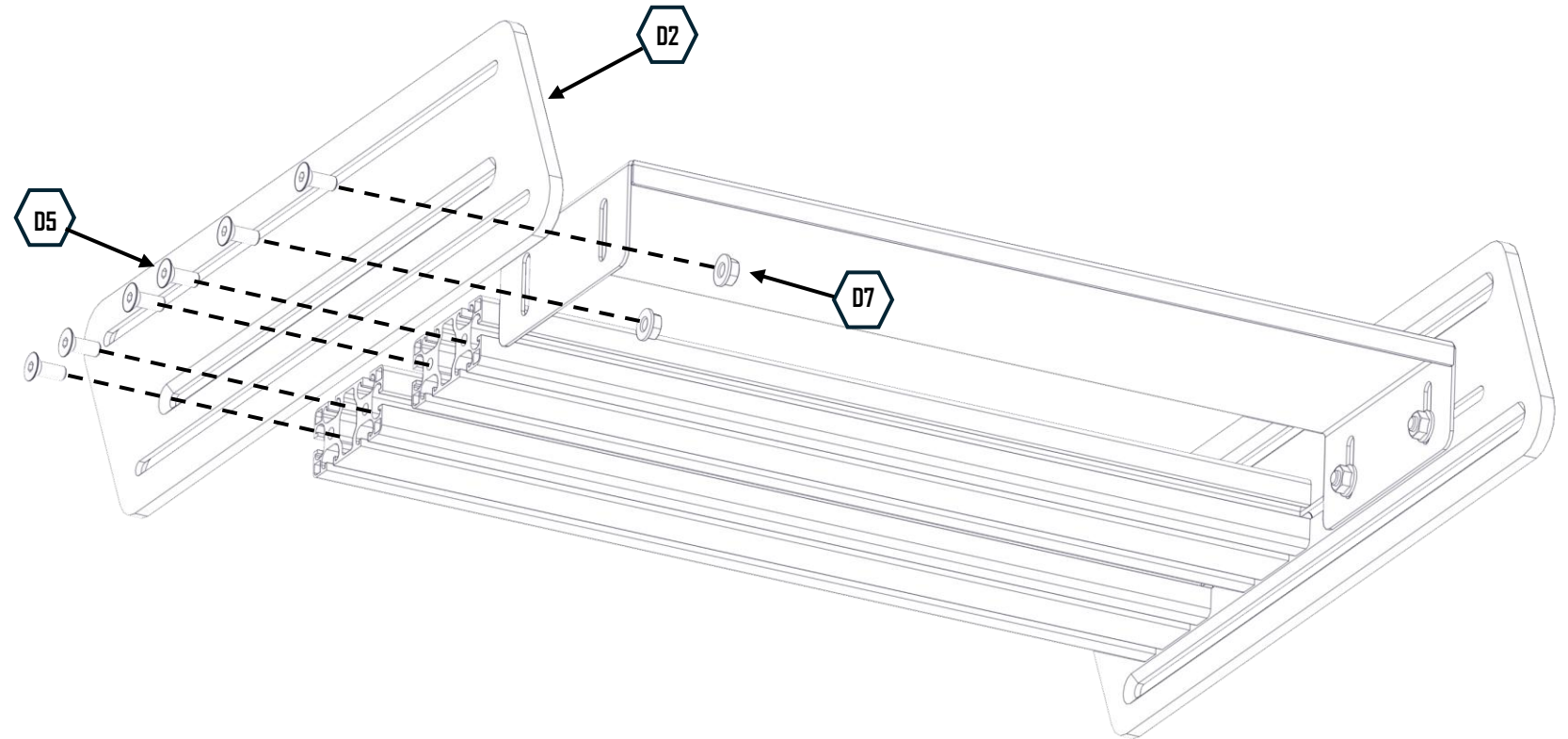

The pedal unit is finished.

Next step: Mounting to the base frame.

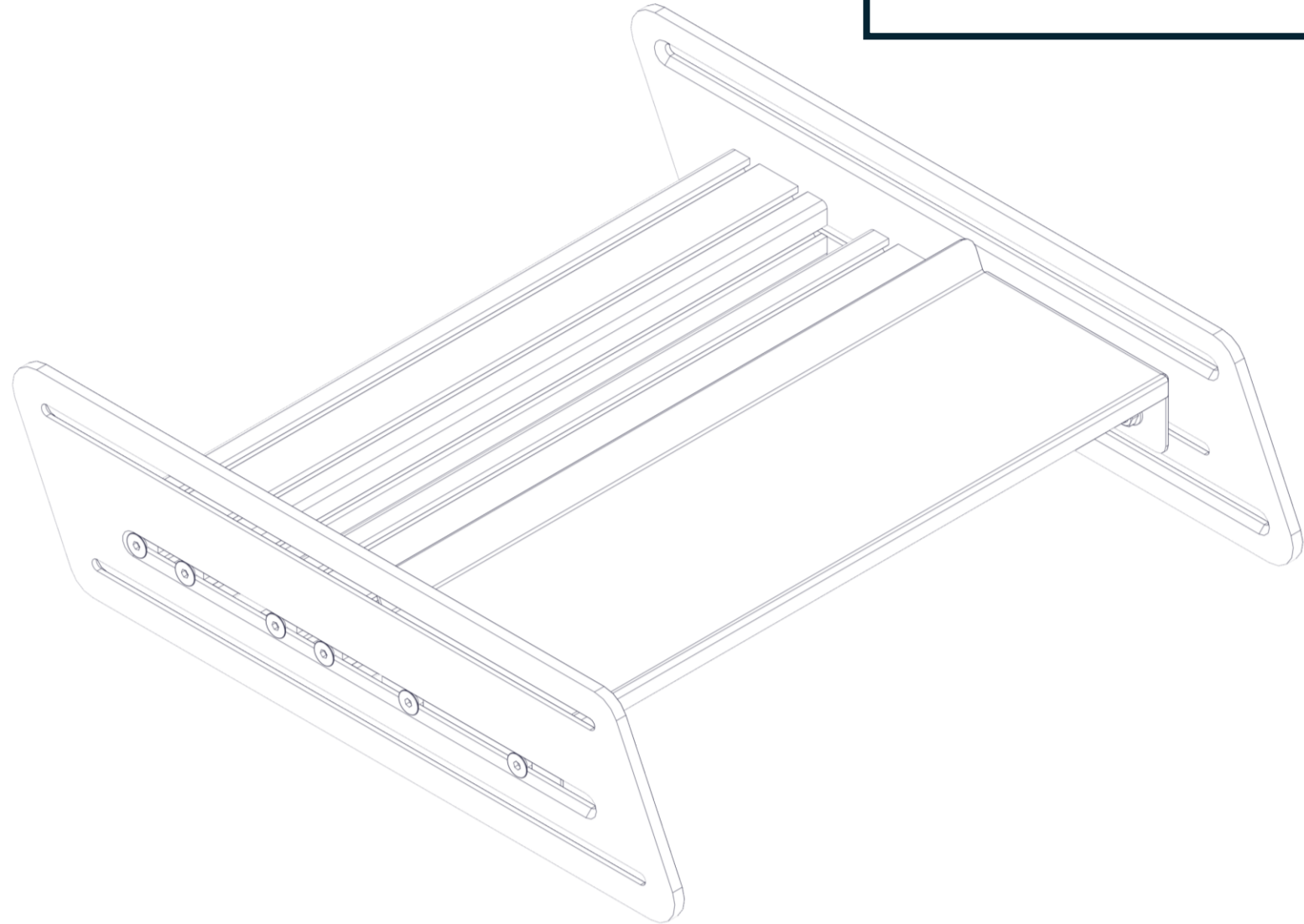

33 / 43

8x
D6

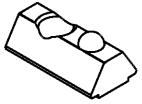

D6



Insert all eight T-nuts into the frame. Four on the left and four on the right.

If you want to mount the pedals in the lowest position, you only need to install three on each side, as the pedal unit can then only be fastened by three screws on each side.

(The marked T-nut must then be removed.)

PEDAL UNIT

34 / 43



Mount the pedal unit on both sides using the eight (D5) countersunk screws (M8 x 20 mm).

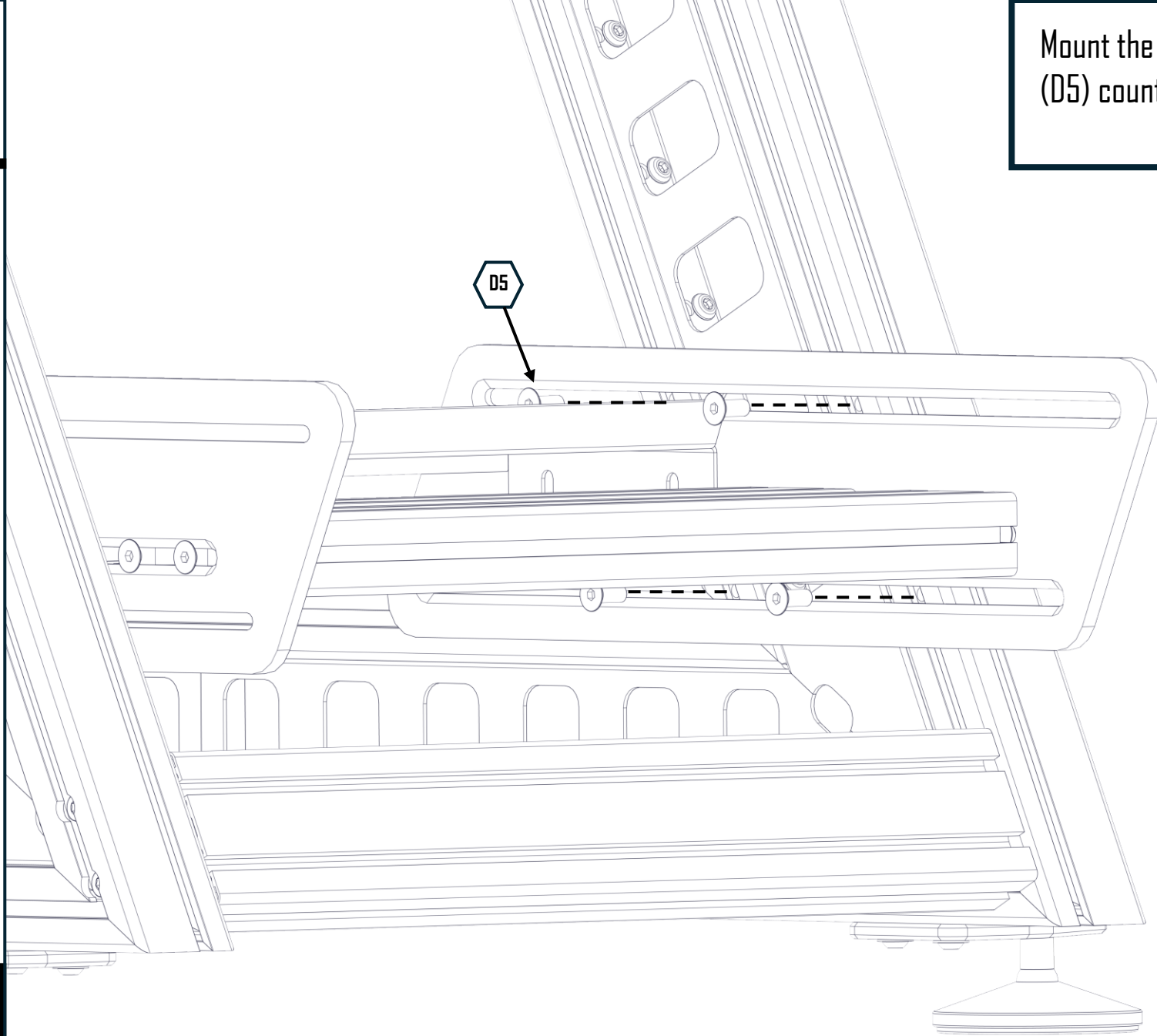

PEDAL UNIT

If you bought following addons for your rig, continue with steps 34-37 after you installed these addons.

- Single Screen Holder
- TripleScreen Holder
- LED-Kit

Read the manual of the addon and come back here after you finished the install.

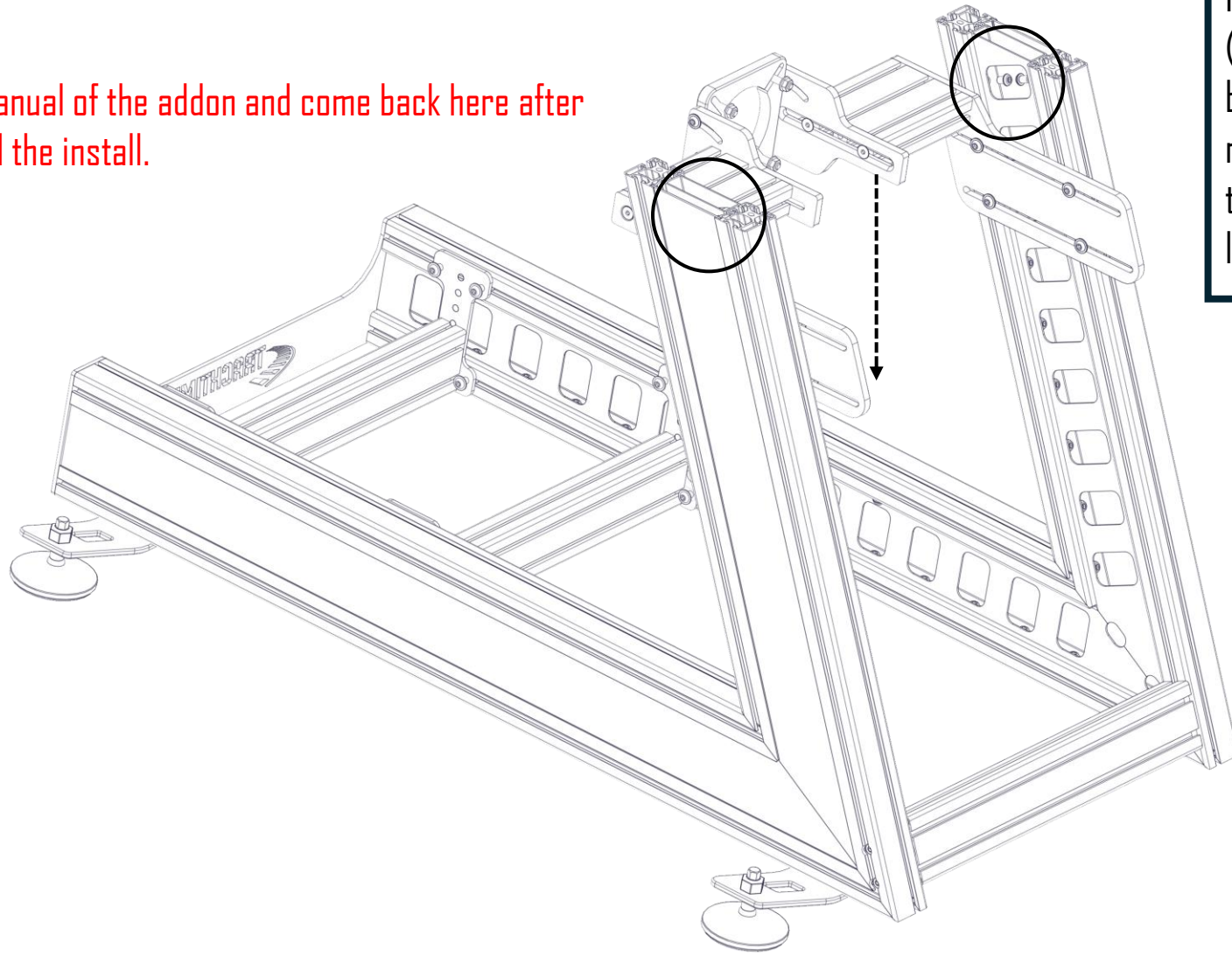

Lower the wheel mount if it covers the upper (A21) M8x12 screws.

Remove the upper 2x (A21) M8x12 screws on both, the left and the right side and put them aside for the later reinstall.

2x A24

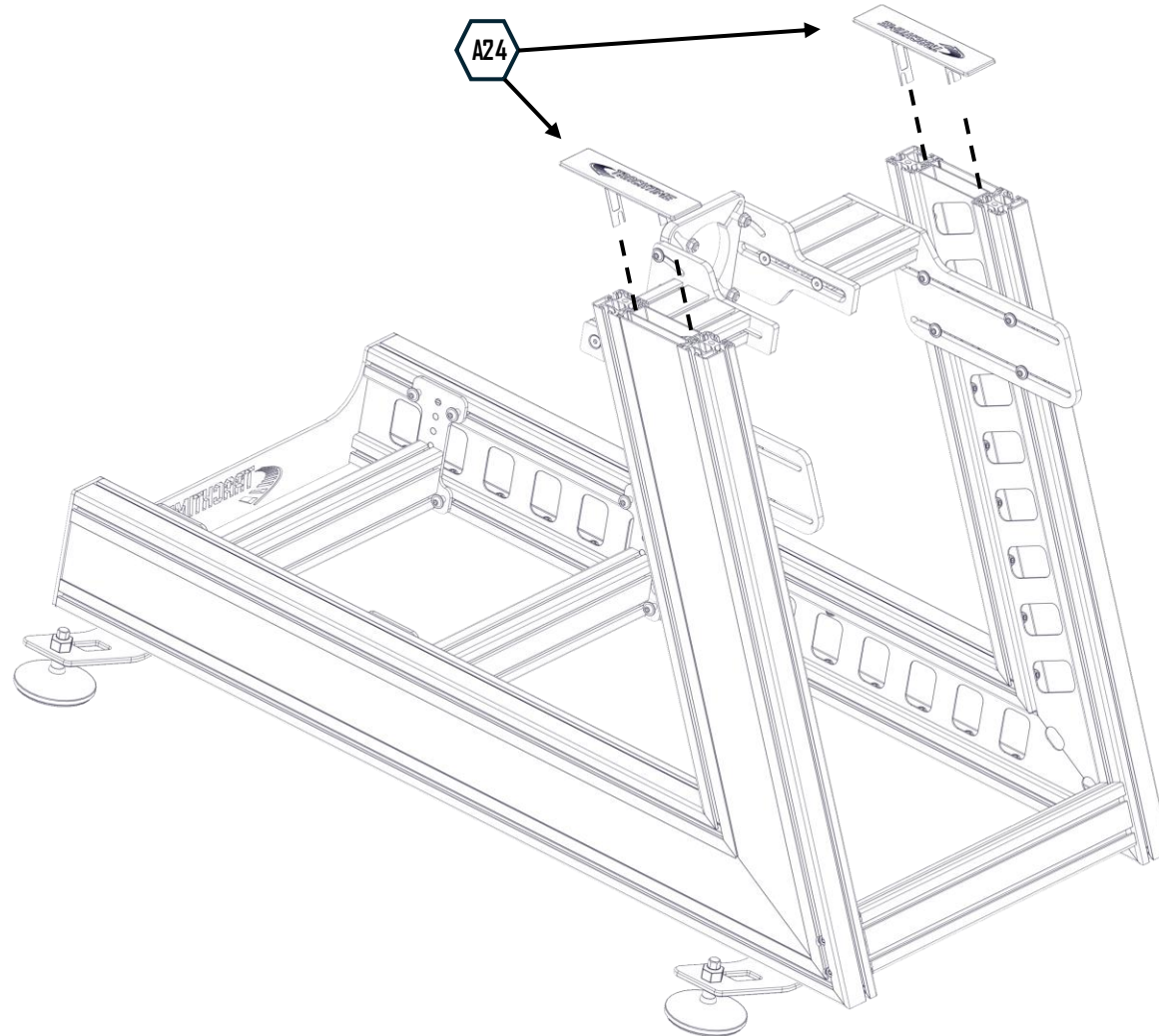

Install both (A24) Endcaps.
Slide them into the top ends of
the (A1) and (A2) Baseangles .

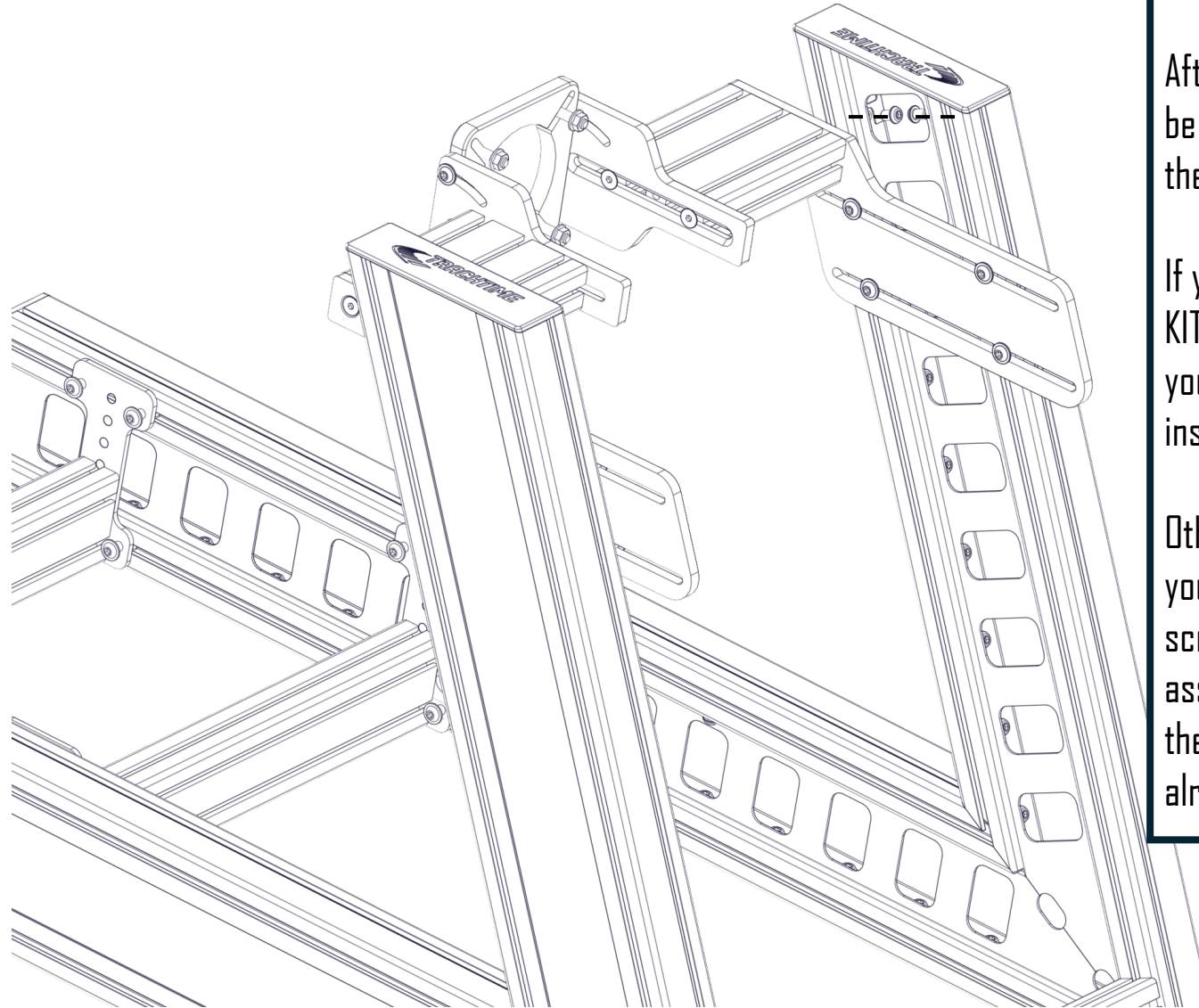

Reinstall the 4x (A21) M8x12 screws.

After that, the Endcaps cannot be removed without loosening these screws.

If you plan to install the LED KIT later, or want to exchange your cover panels, don't install these screws.

Otherwise you need to lower you wheel Unit to reach these screws which requires the assist of a second person if the heavy Wheel system is already installed.

Readjust the position of your wheel unit.

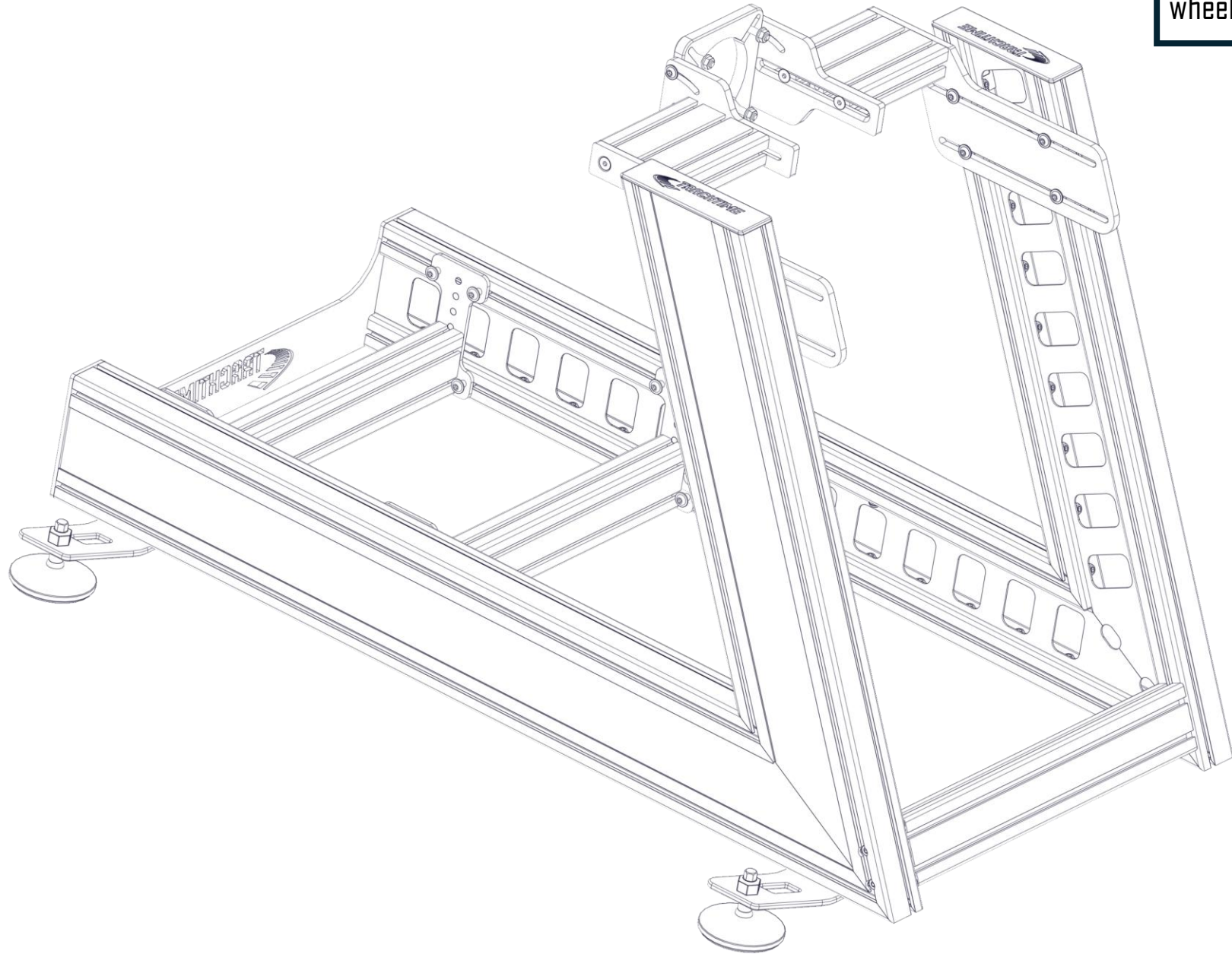

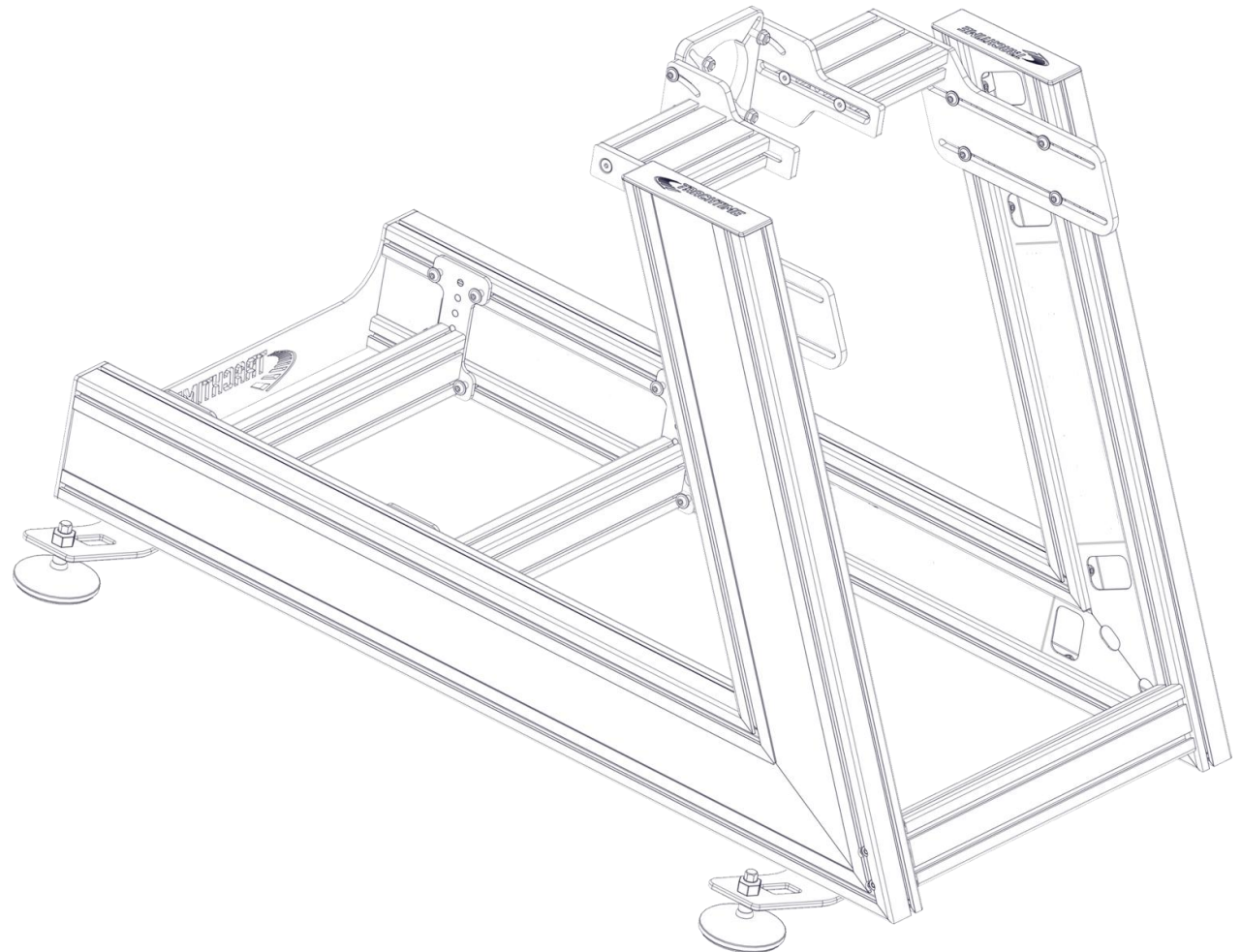

When every cable is installed feel free to use the provided magnet foil pieces to cover the frame cutouts. The material can be cut with regular scissors.

Asetek

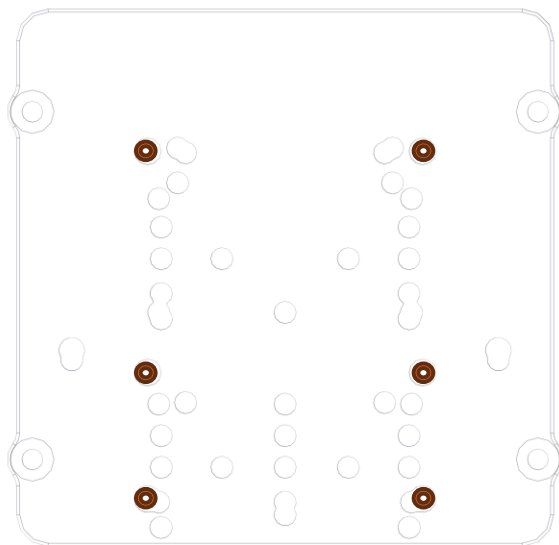

Fanatec CSW

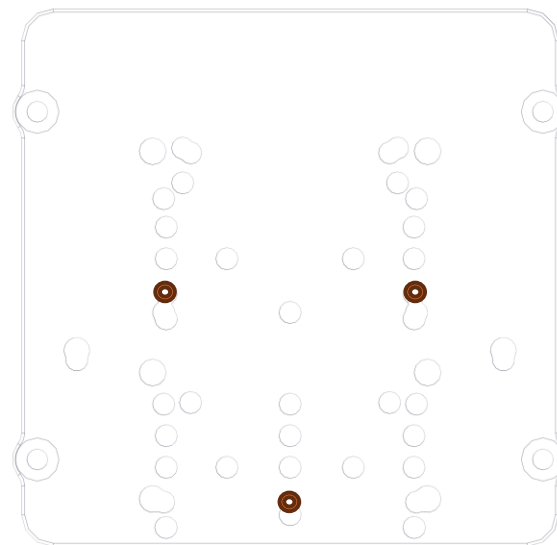

Fanatec DD1 / DD2

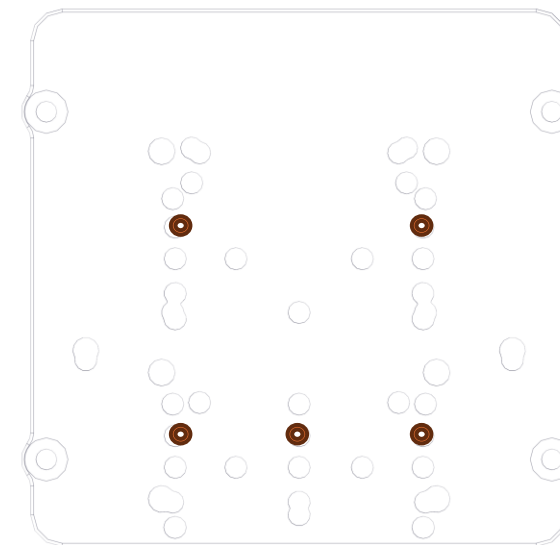

Fanatec CSL DD

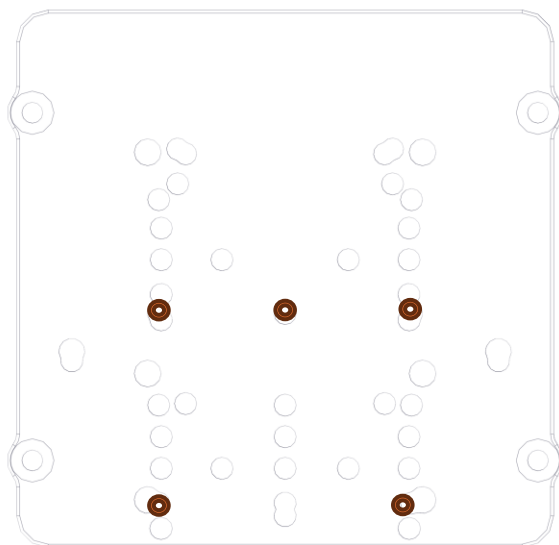

Fanatec DD / DD+

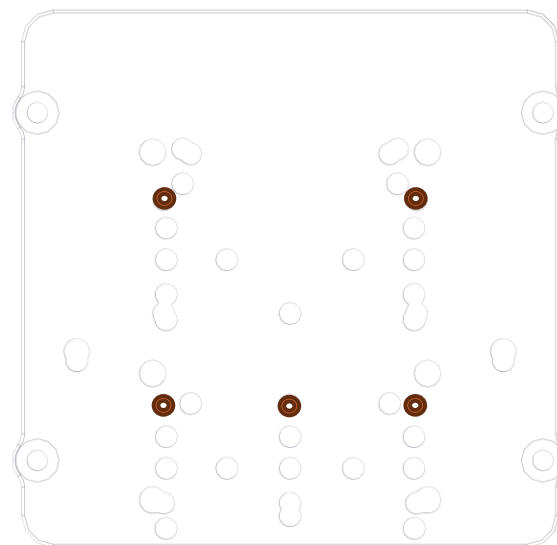

Logitech G25 / G27 / G920 / G923

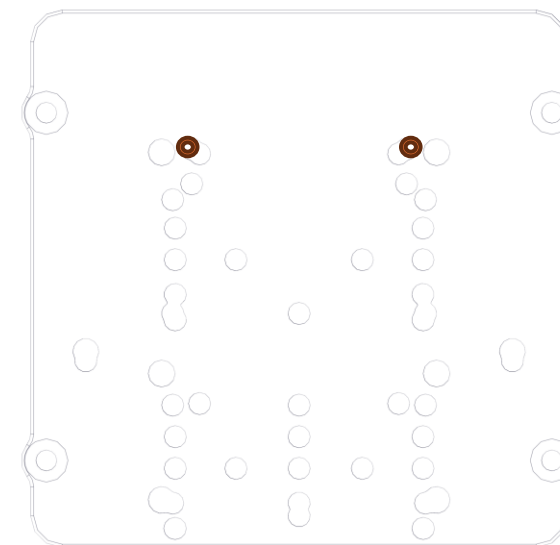

Logitech Pro Racing Wheel

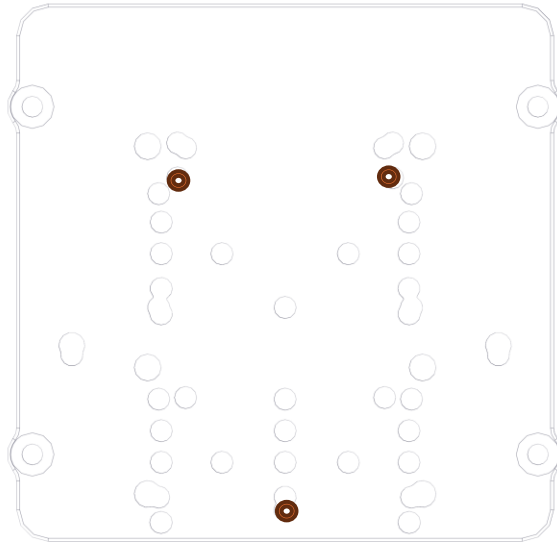

Moza R5, R9, R12

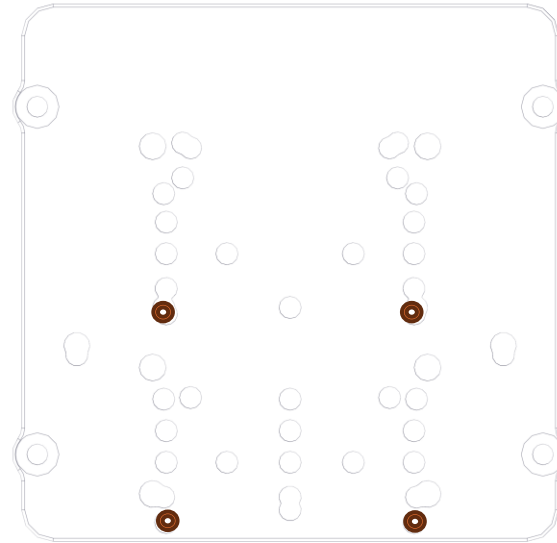

Simagic Alpha

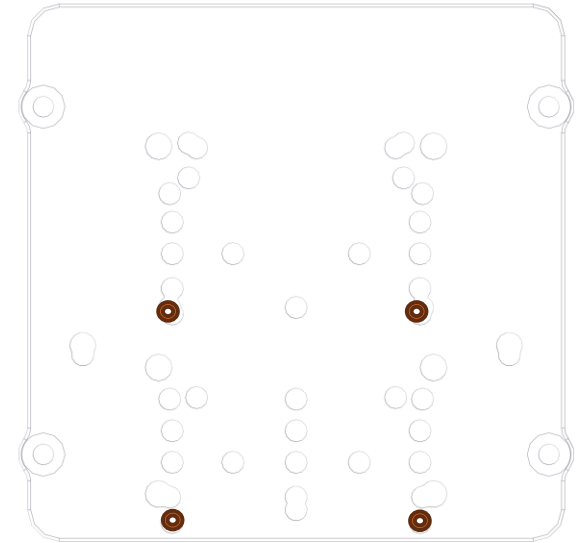

Thrustmaster T818

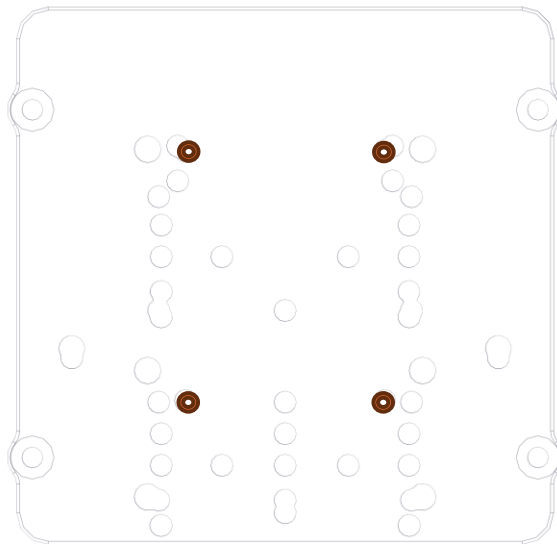



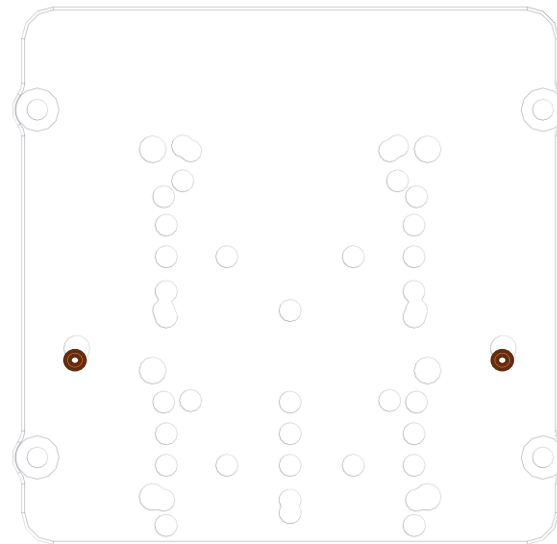

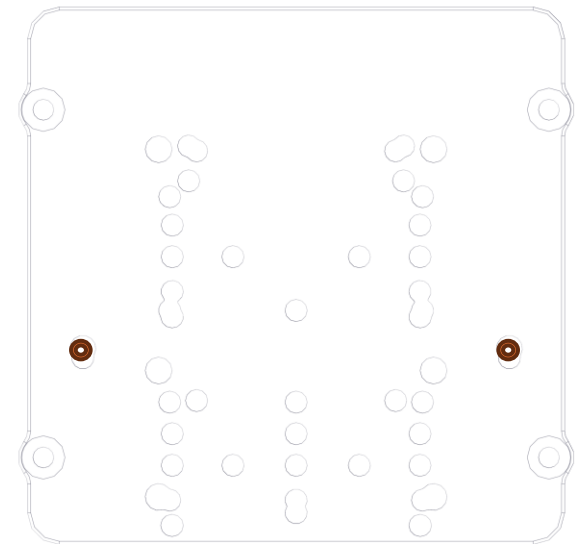

Thrustmaster T-GT, T-GT2





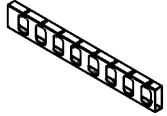



Thrustmaster T300, T248,
T500, TC-PC, TS-XW









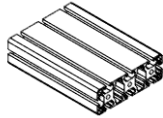

75105648 Series One Base Frame



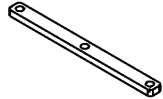
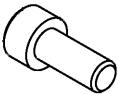
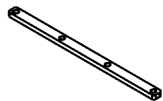
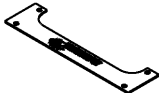

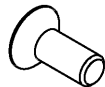
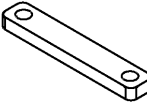

Part	Picture	Order. No.	Article	Pieces
A1		75105646	Baseangle right	1
A2		75105647	Baseangle left	1
A3		75121111	Baseprofile	2
A4		75121187	Steering Column Right Front Aluminium Extrusion 817mm	1
A5		75121114	Steering Column Left Front Aluminium Extrusion 817mm	1
A6		75121115	Steering Column Left Rear Aluminium Extrusion 636mm	1

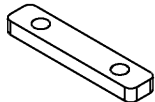

Part	Picture	Order. No.	Article	Pieces
A7		75121188	Steering Column Right Rear Aluminium Extrusion 636mm	1
A8		75121116	Frame Upper Left Aluminium Extrusion 1022mm	1
A9		75121189	Frame Upper Right Aluminium Extrusion 1022mm	1
A10		75121190	Frame Lower Right Aluminium Extrusion 1218mm	1
A11		75121117	Frame Lower Left Aluminium Extrusion 1218mm	1
A12		75121121	Seatholder Aluminium Extrusion 80x40 510mm	2

75105648 Series One Base Frame

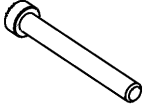

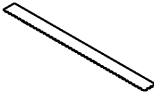
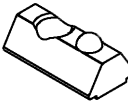

Part	Picture	Order. No.	Article	Pieces	Part	Picture	Order. No.	Article	Pieces
A13		75121144	Wheelunit Aluminium Extrusion 120x80 165mm	2	A19		68320244	Lensflatscrew M8x16	16
A14		75121175	Cross Support Aluminium Extrusion 80x40 520mm	1	A20		68320334	Countersunkscrew M8x16	8
A15		75121118	Long T-Nut M8 3-Units	20	A21		68320760	Lensscrew M8x12	92
A16		75121119	Long T-Nut M8 4-Units	8	A22		75121143	Rear Plate	1
A17		75121120	Seatholder Bracket	4	A23		68320617	Countersunkscrew M8x20	8
A18		75121122	Long T-Nut M8 2-Units	8	A24		75130318	Angled Extrusion Cap left 160x40	1

75105648 Series One Base Frame

Part	Picture	Order. No.	Article	Pieces
A25		75130325	Angled Extrusion Cap right 160x40	1
A26		75121172	Footbracket	4
A27		75121173	Footbracket T-Nut	4
A28		68320181	Lensscrew M8x20	16
A29		68320109	Cylinderscrew M8x65	4
A30		75190071	Footunit	4

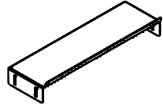

Part	Picture	Order. No.	Article	Pieces
A31		75190072	Flexible Magnet Cover 2x1200mm & 2x800mm	1
A32		75190016	T-Nut M8	8
A33		75121152	Wheelbracket left	1
A34		75121153	Wheelbracket right	1

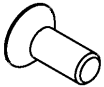
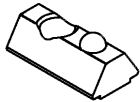

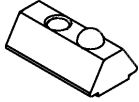
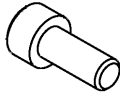
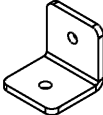
75105654 Pedal Unit

Part	Picture	Order. No.	Article	Pieces
D1		75121136	Footplate	1
D2		75121141	Pedalbracket left	1
D3		75121142	Pedalbracket right	1
D4		75121140	Pedalcarrier Aluminium Extrusion 80x40 504mm	12
D5		68320617	Countersunkscrew M8x20	20
D6		75190016	T-Nut M8	8

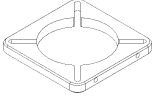
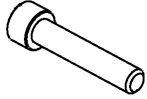

Part	Picture	Order. No.	Article	Pieces
D7		68310044	Locknut M8	4
D8		75190065	T-Nut M5	12
D9		68320576	Cylinder Screw M5x12	12
D10		75121178	Angle Bracket	4

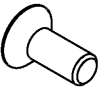
75105666 Front Wheel Mount

Part	Picture	Order. No.	Article	Pieces
H1		75121149	Motor Plate	1
H2		68320073	Cylinder Screw M8x40	4
H3		68310095	Locknut M8	4
H4		75121147	Wheelbracket left	1

Part	Picture	Order. No.	Article	Pieces
H6		75121148	Wheelbracket right	1
H7		68320617	Countersunkscrew M8x20	4
H8		68320181	Lensscrew M8x20	4

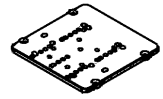
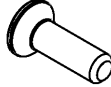
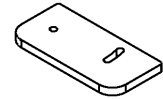
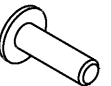
75105667 Top Wheel Mount

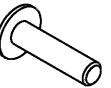
Part	Picture	Order. No.	Article	Pieces	Part	Picture	Order. No.	Article	Pieces
11		75121184	Topmount Wheelplate	1	14		68320404	Countersunkscrew M6x20	4
12		75121185	Topmount Wheelbracket	2	15		68320183	Lensflatscrew M6x20	4
13		68320181	Lensscrew M8x20	8	16		68320382	Lensscrew M5x20	4

75105669 Cover transparent

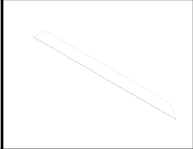
Part	Picture	Order. No.	Article	Pieces
K1		75130301	Upper Cover	2
K2		75130302	Lower Cover	2

75105670 Cover with CFK skin

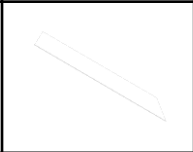
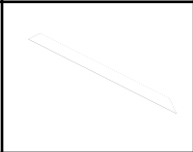
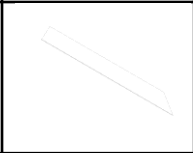
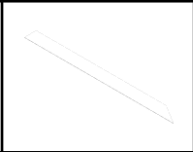
Part	Picture	Order. No.	Article	Pieces
L1		75105670	Upper Cover left	1
L2		75105670	Lower Cover left	1
L3		75105670	Upper Cover right	1
L4		75105670	Lower Cover right	1

Need help? Scan for help & resources

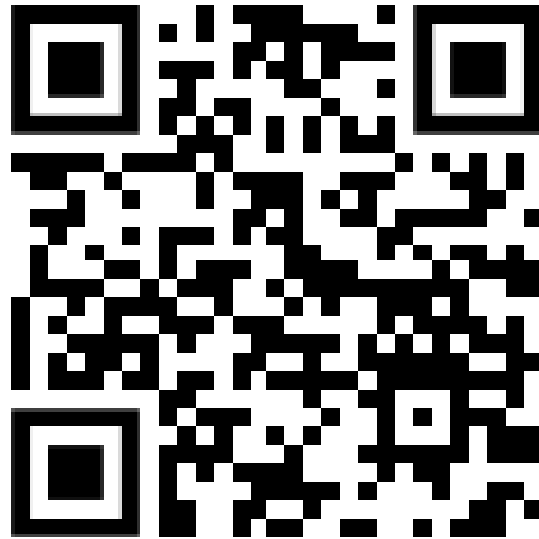

If you have any further questions about assembling this product or about the manual itself, please contact our support department. You can reach them at

info@track-time.de