

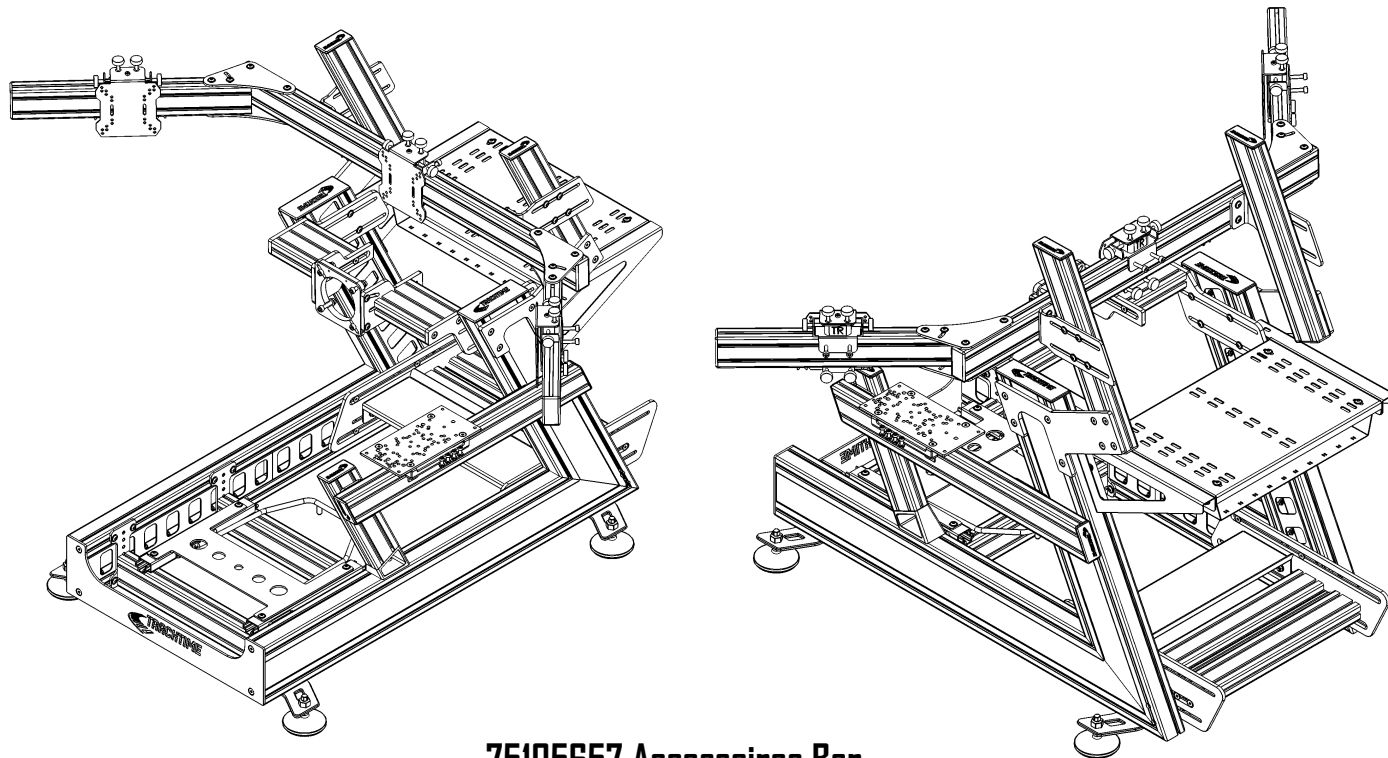

series / one



75105657 Accessoires Bar

Version 1.1

BEFORE STARTING THE BUILD

The following are needed for assembly:

- Soft base / underlay (scratch protection)
- Tape measure/ruler

Read the manual first. All remarks are important and could help you avoid problems.

Use BOM (Bill of Material) to find the sizes and lengths of the parts.



3 / 11

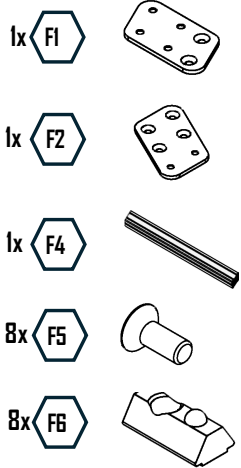

ACCESSOIRES BAR

Use the (F5) M8x20 Countersunk Screws and (F6) T-Nuts to mount both brackets.

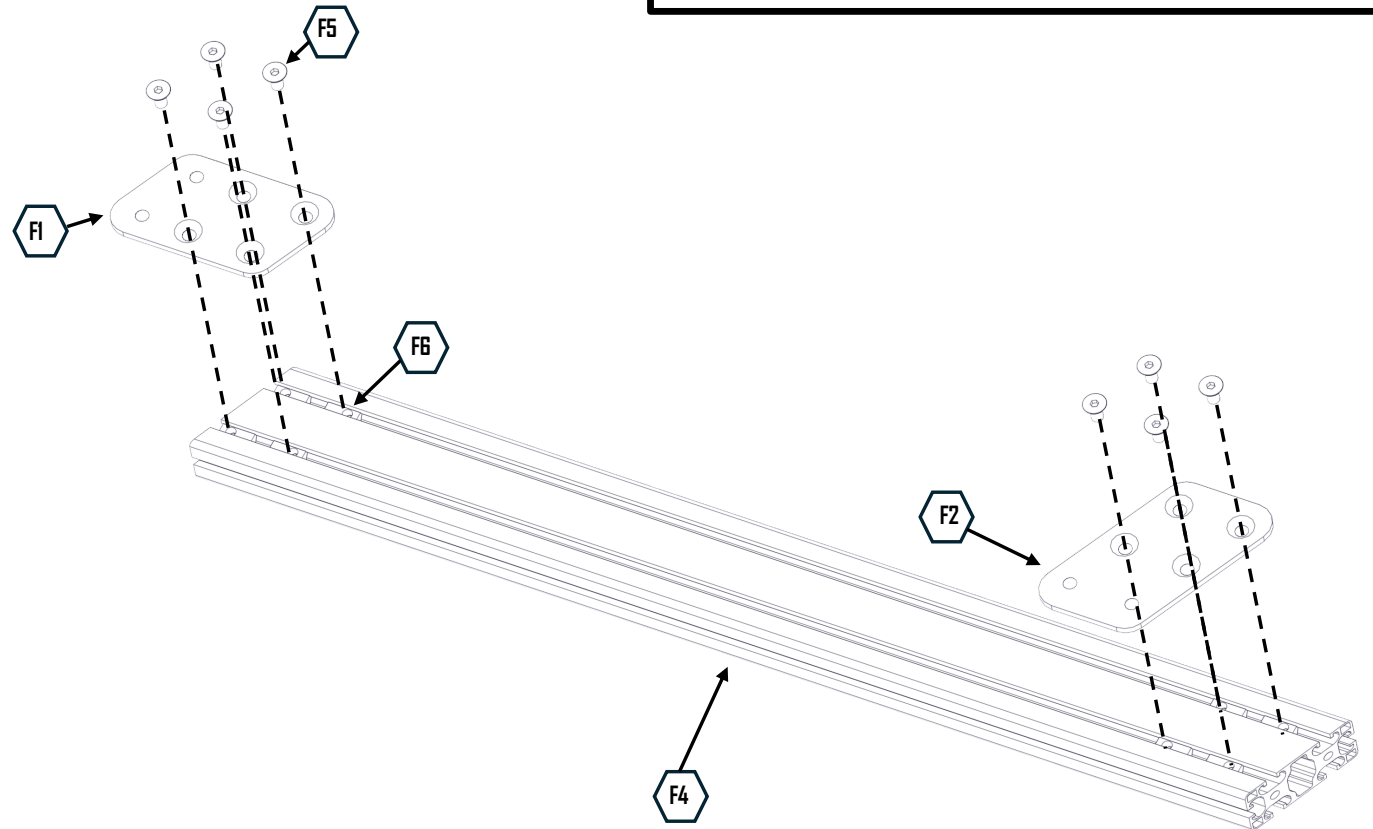

4 / 11

The result after step 1



ACCESSOIRES BAR

5 / 11

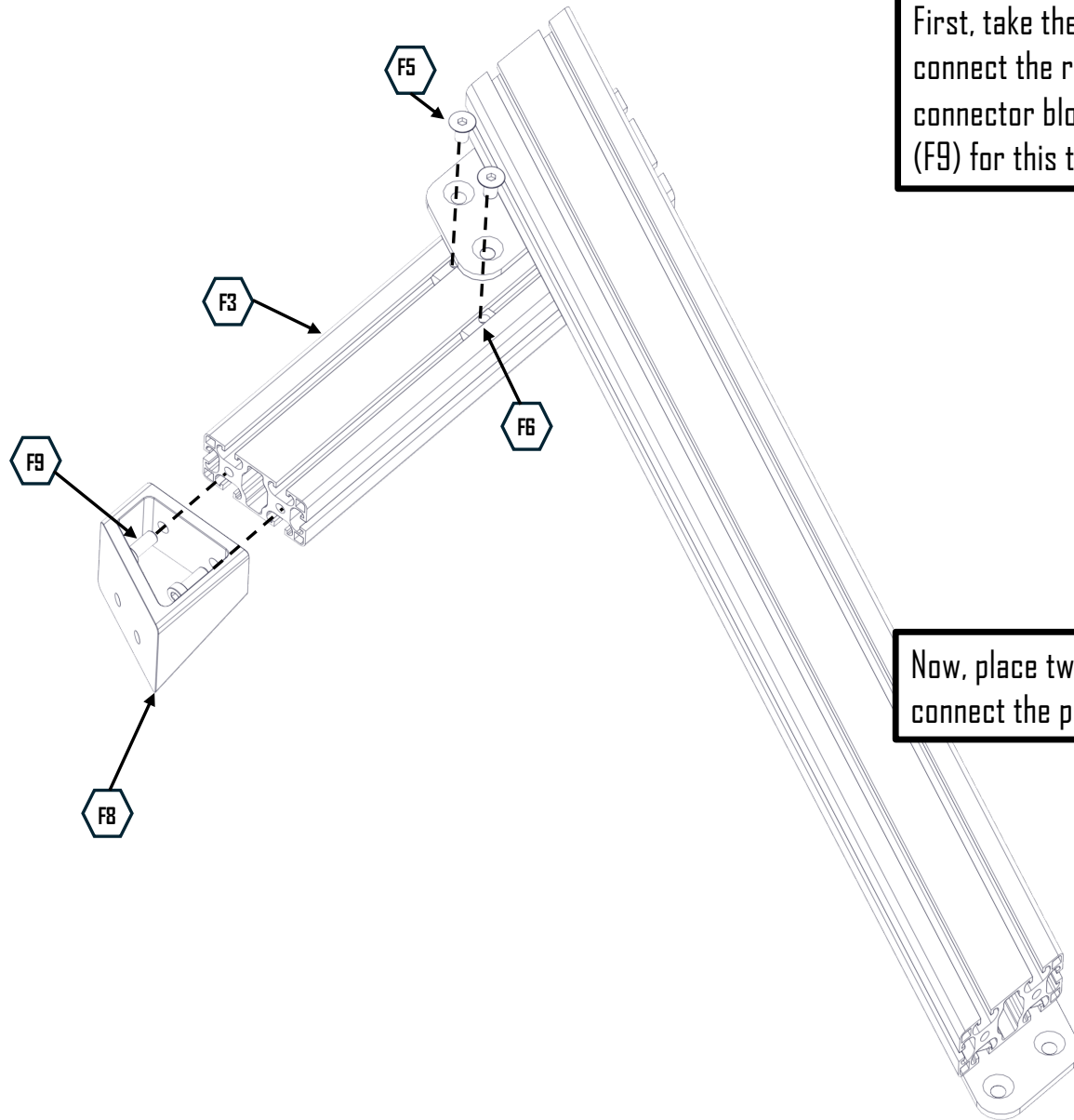
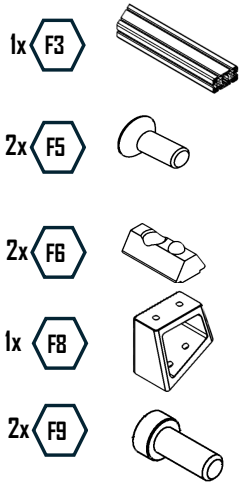

First, take the shorter aluminium extrusion (F3) and connect the right-angled end with the aluminium connector block (F8). Use the M8x20 cylinder screws (F5) for this task.

Now, place two T-nuts in the slots of the extrusion and connect the pre-assembled unit from step 1.

6 / 11

The result after step 3:

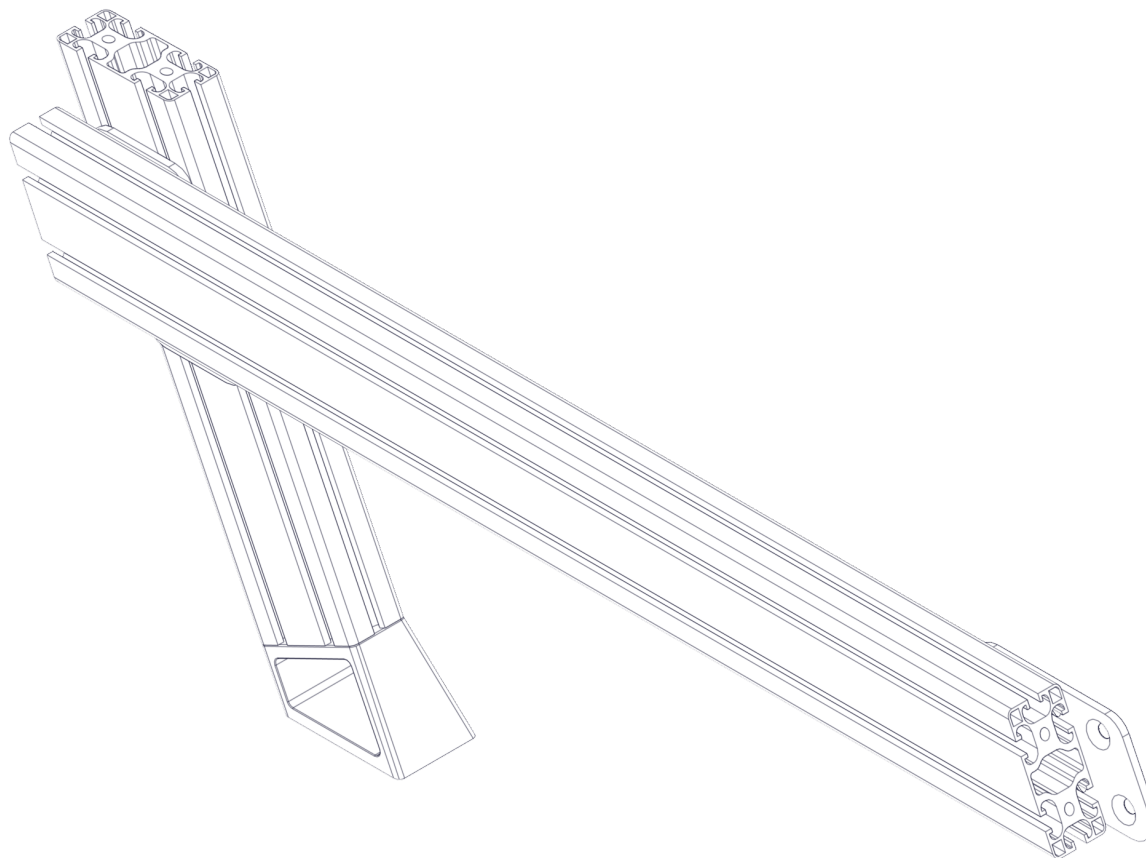

ACCESSOIRES BAR

7 / 11



ACCESSOIRES BAR

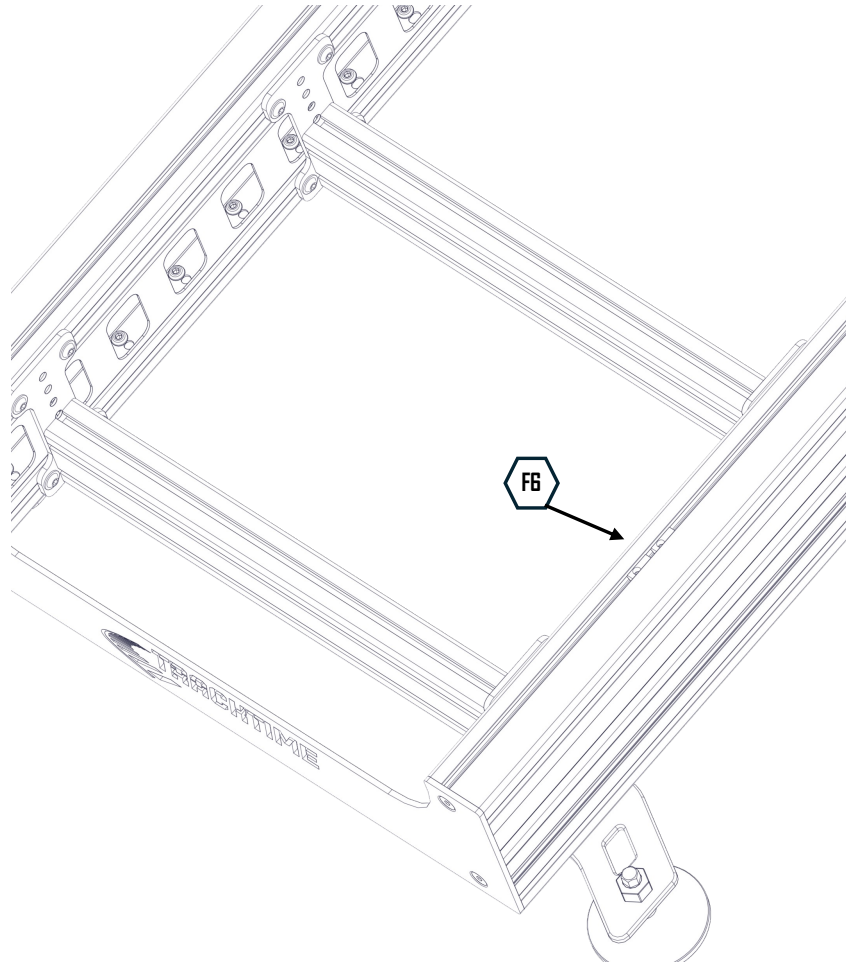

Install four (F6) M8 T-Nuts now.

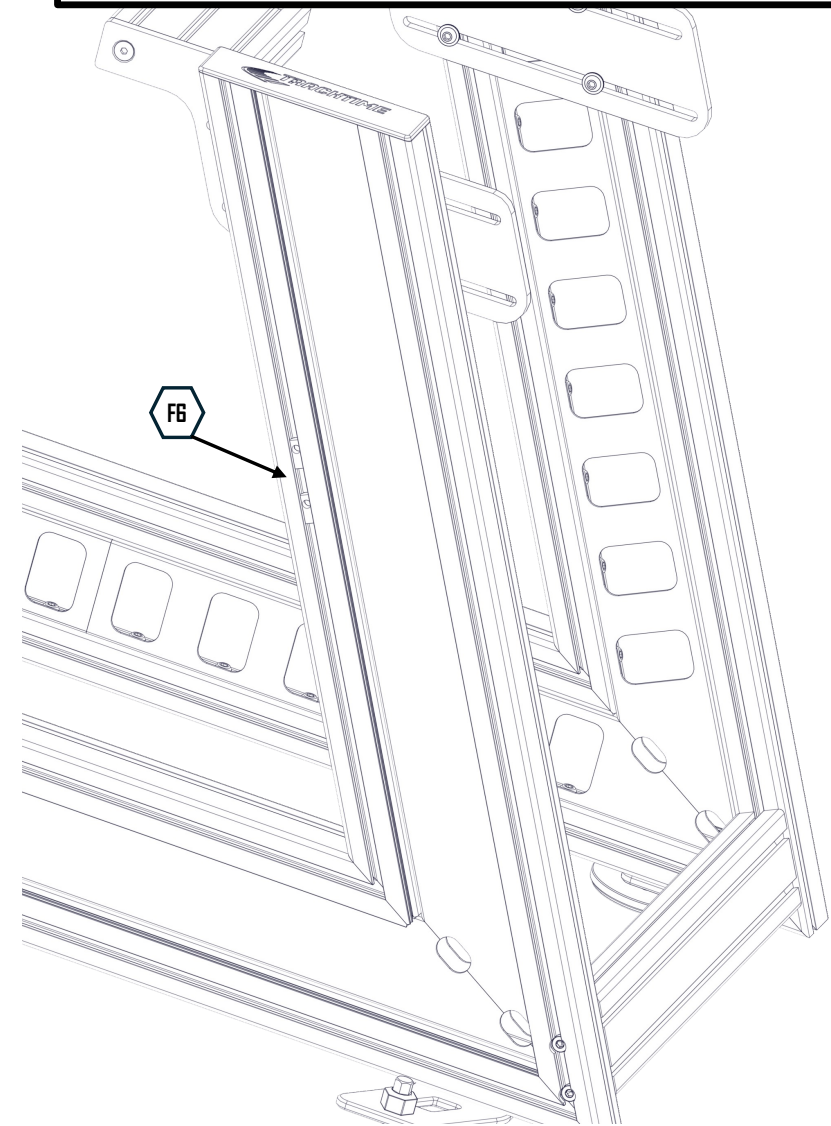

8 / 11

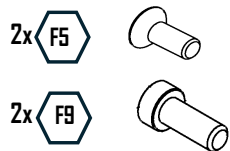

ACCESSOIRES BAR

Mount the accessories bar using the (F5) M8x16 countersunkscrews and the (F9) M8x20 cylinderscrews.

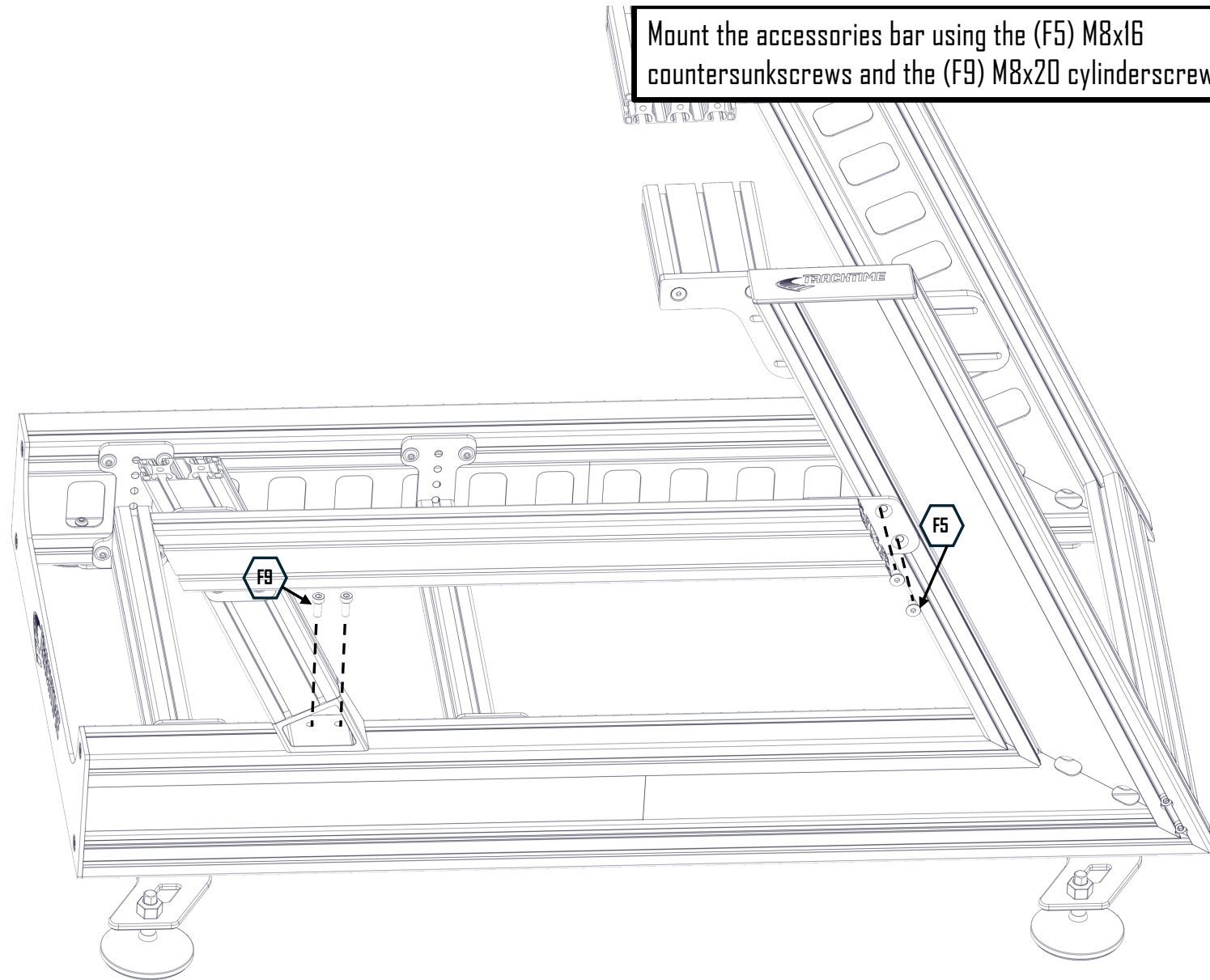

9 / 11

3x F7



F7

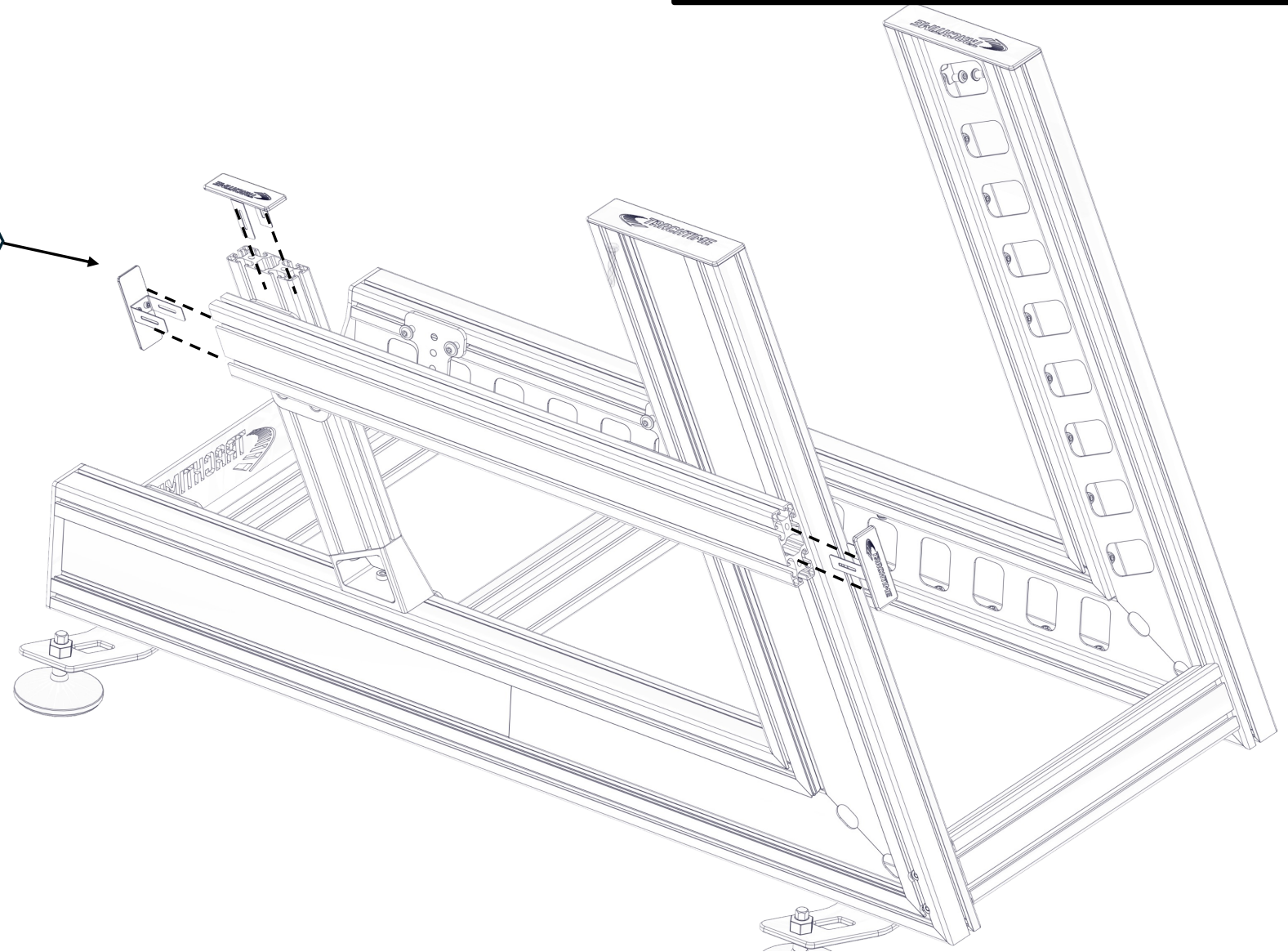

Now, install the three (F7) end caps.

ACCESSOIRES BAR



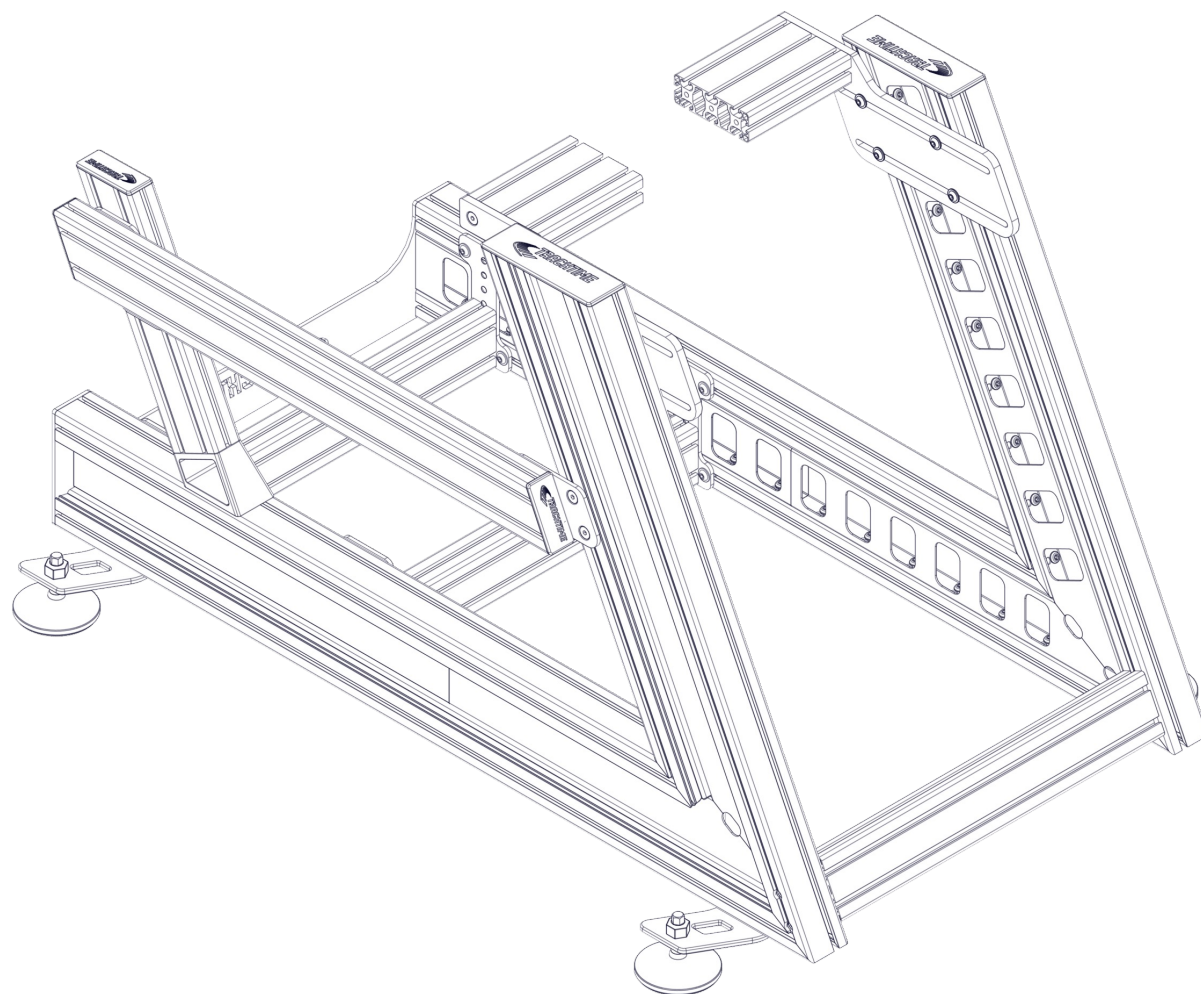

10 / 11



Finished



ACCESSOIRES BAR

75105657 Accessoires Bar

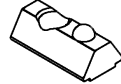
Part	Picture	Order. No.	Article	Pieces
F1		75121157	Bracket Frontframe	1
F2		75121158	Bracket Shifterbar	1
F3		75121159	Vertical Support Aluminium Extrusion 80x40 358mm	1
F4		75121160	Accessoires Bar Alumium Extrusion 80x40 760mm	1
F5		68320334	Countersunkscrew M8x16	12

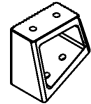
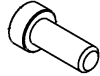
Part	Picture	Order. No.	Article	Pieces
F6		75190016	T-Nut M8	14
F7		75130319	Angled Extrusion Cap 80x40	3
F8		75121192	Connector Block	1
F9		68320247	Cylinderscrew M8x20	4



series / one

Need help? Scan for help & resources



If you have any further questions about assembling this product or about the manual itself, please contact our support department. You can reach them at

info@track-time.de