

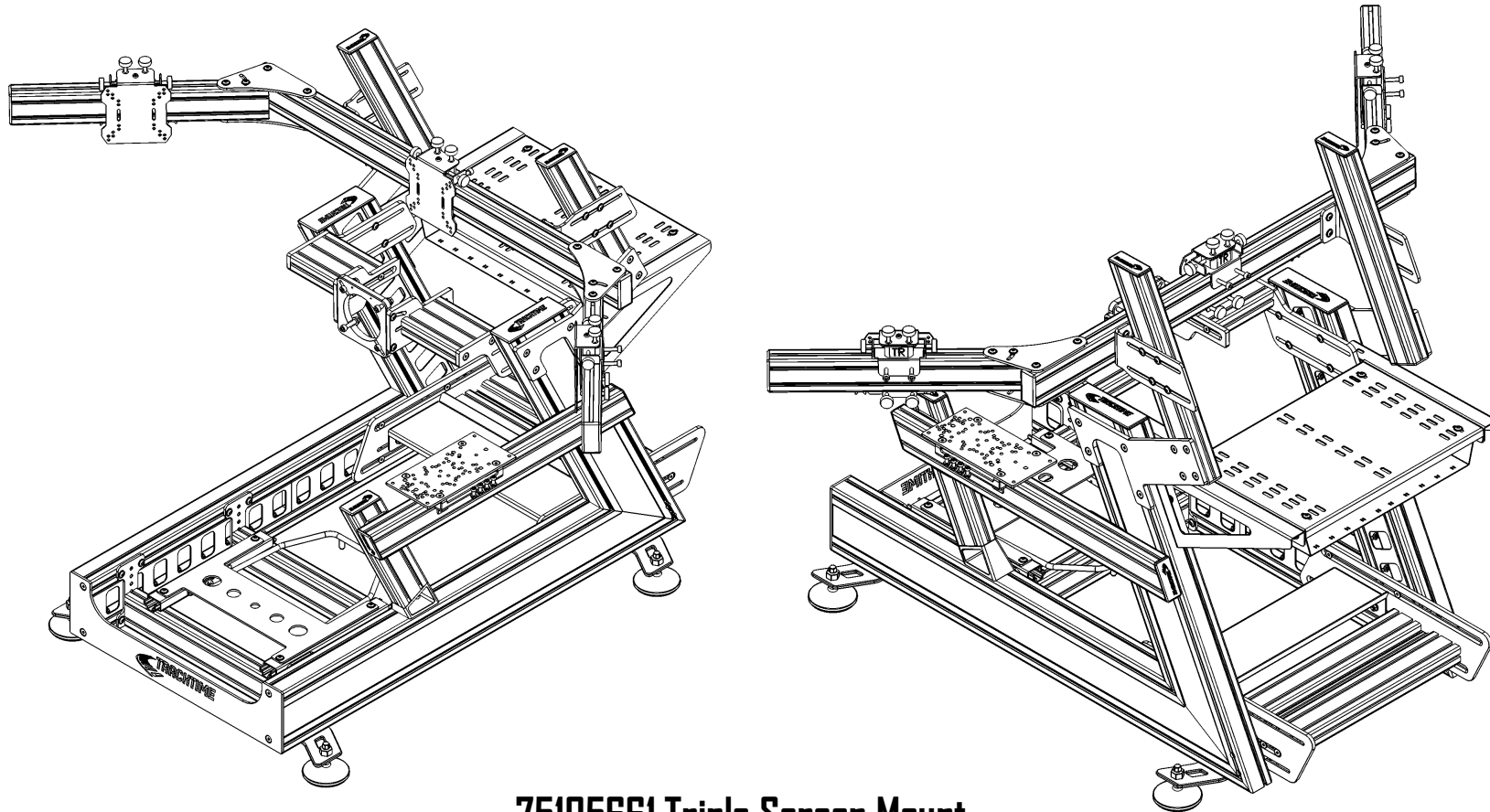

series / one



75105661 Triple Screen Mount

Version 1.1

BEFORE STARTING THE BUILD

The following are needed for assembly:

- A set of hex wrenches
- Tape measure /ruler
- Level

Read the manual first. All remarks are important and could help you avoid problems.

Use BOM (Bill of Material) to find the sizes and lengths of the parts.



BEFORE STARTING THE BUILD

NOTE: This kit includes an additional bag of replacement screws.





You receive two screw packs with this kit.

One pack contains the **regular non-oily screws**, while the other contains **oily spare screws**.

The oily screws included in the kit are **replacement screws only** and should be used **only if** the required screws from the main screw pack are not sufficient.

If necessary, end caps and T-nuts can be cleaned with isopropanol.

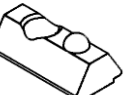

- 1x G10 
- 1x G11 
- 16x G3 
- 16x G16 

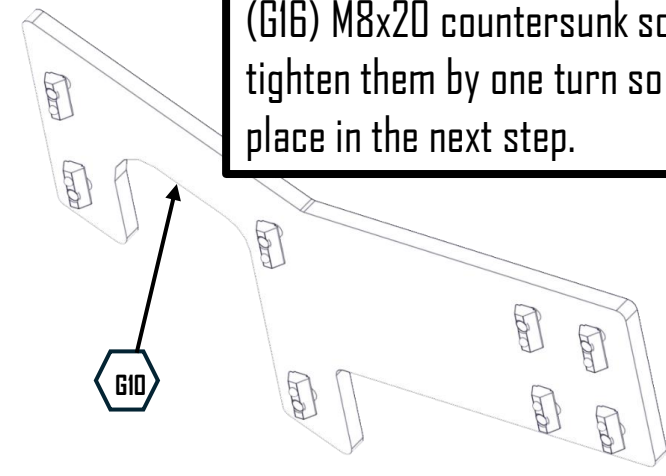
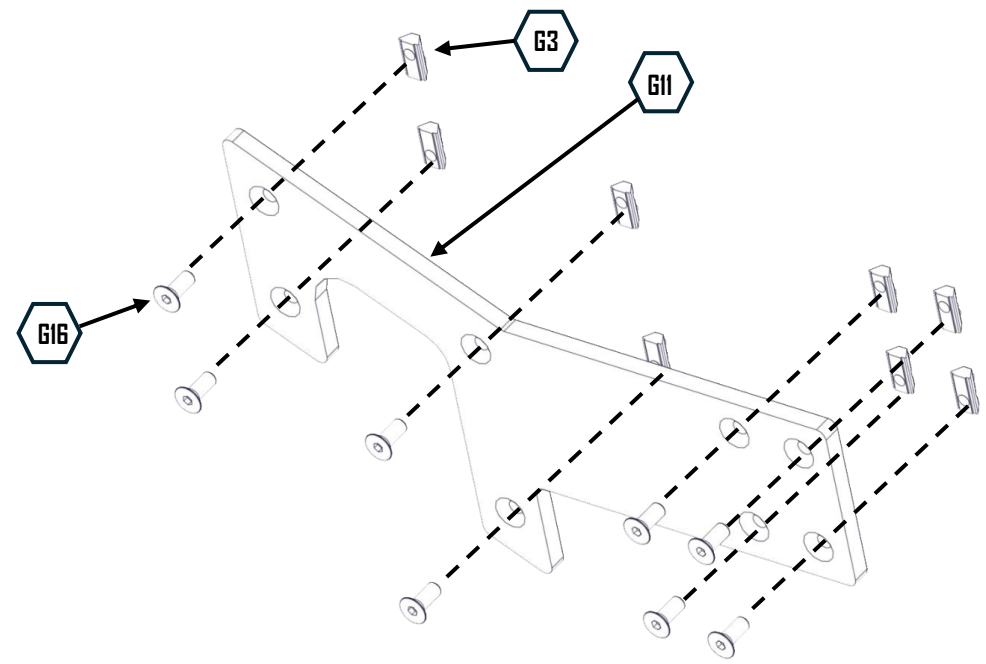

Prepare both monitor main brackets (left and right) with (G16) M8x20 countersunk screws and (G3) M8 T-nuts. Only tighten them by one turn so that they can be slid into place in the next step.

Slot the left and right units into the base frame (the picture shows the upper end cap, which must be removed to do this).

Place them both in the desired position (on both sides at the same height) and tighten all the screws.

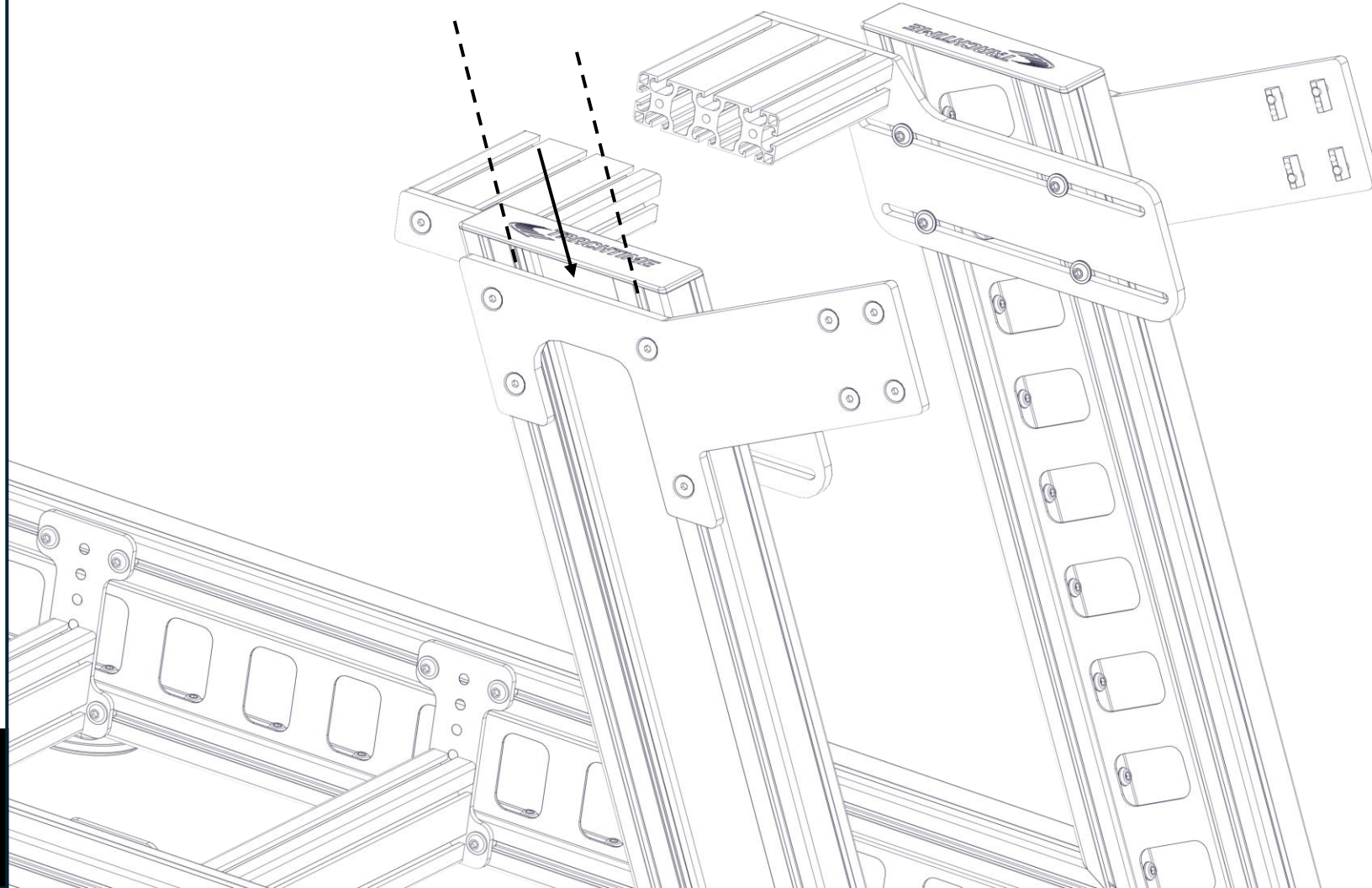

2x G12

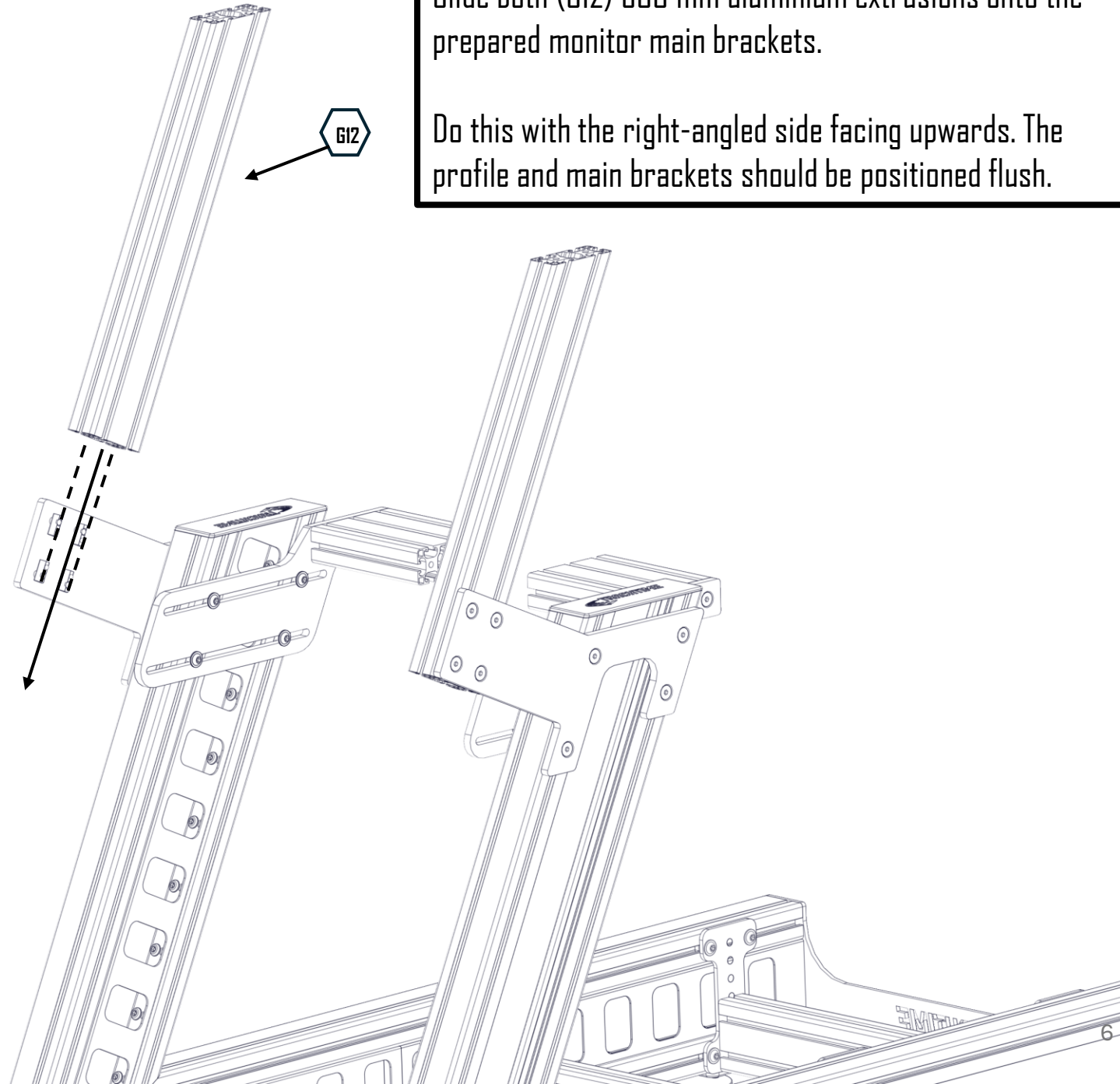

Slide both (G12) 500 mm aluminium extrusions onto the prepared monitor main brackets.

Do this with the right-angled side facing upwards. The profile and main brackets should be positioned flush.

7 / 19

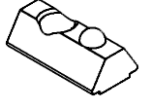

8x G3

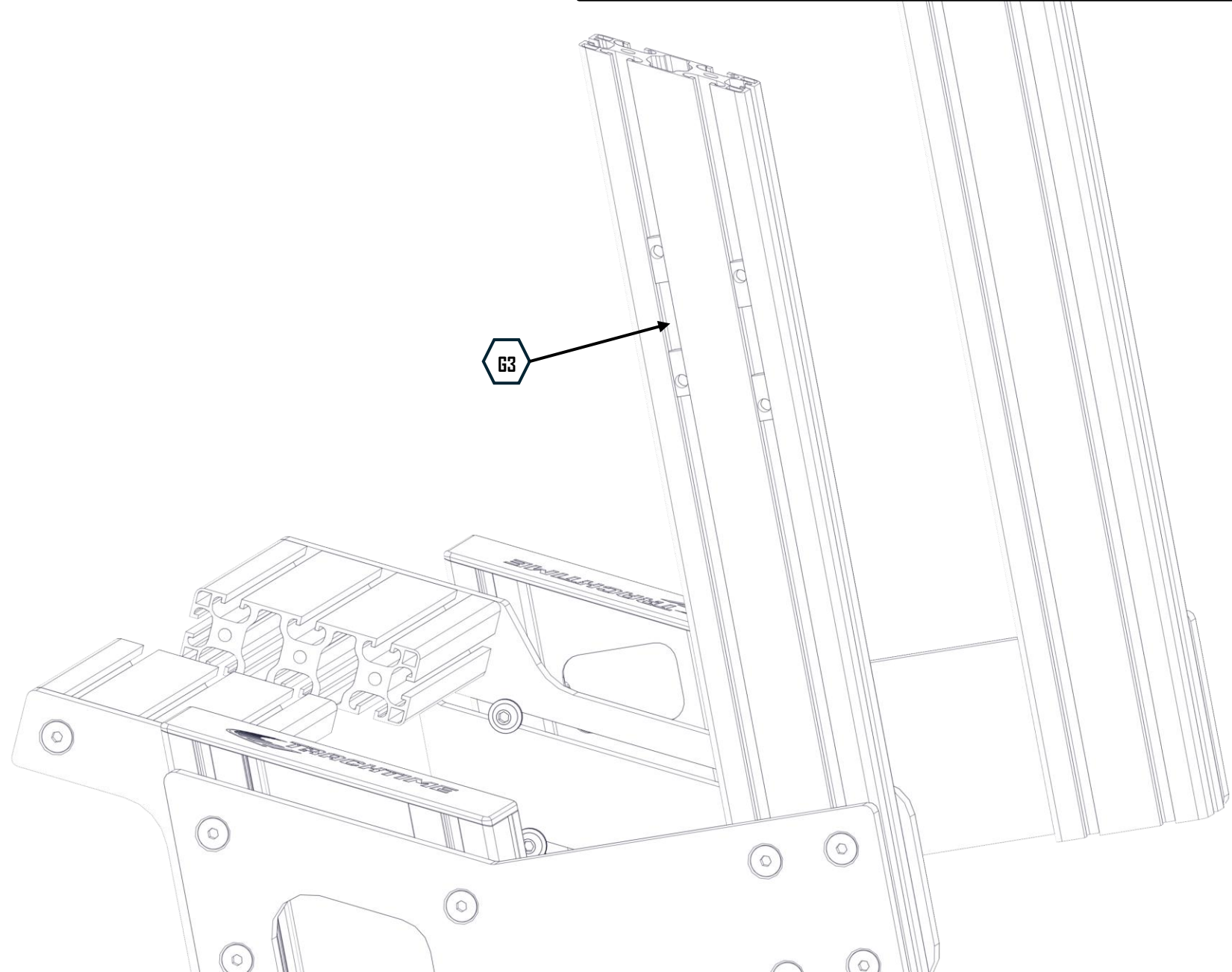

Insert eight (G3) M8 T-Nuts into the extrusion slots (on both outer sides). (On both outer sides).



TRIPLE SCREEN UNIT

- 1x G13 
- 1x G14 
- 8x G17 

Use the (G17) M8x16 screws to mount both monitor slider brackets.

Ensure both sides are perfectly symmetrical and level (Use a level).

This is important for the later cross bar installation.

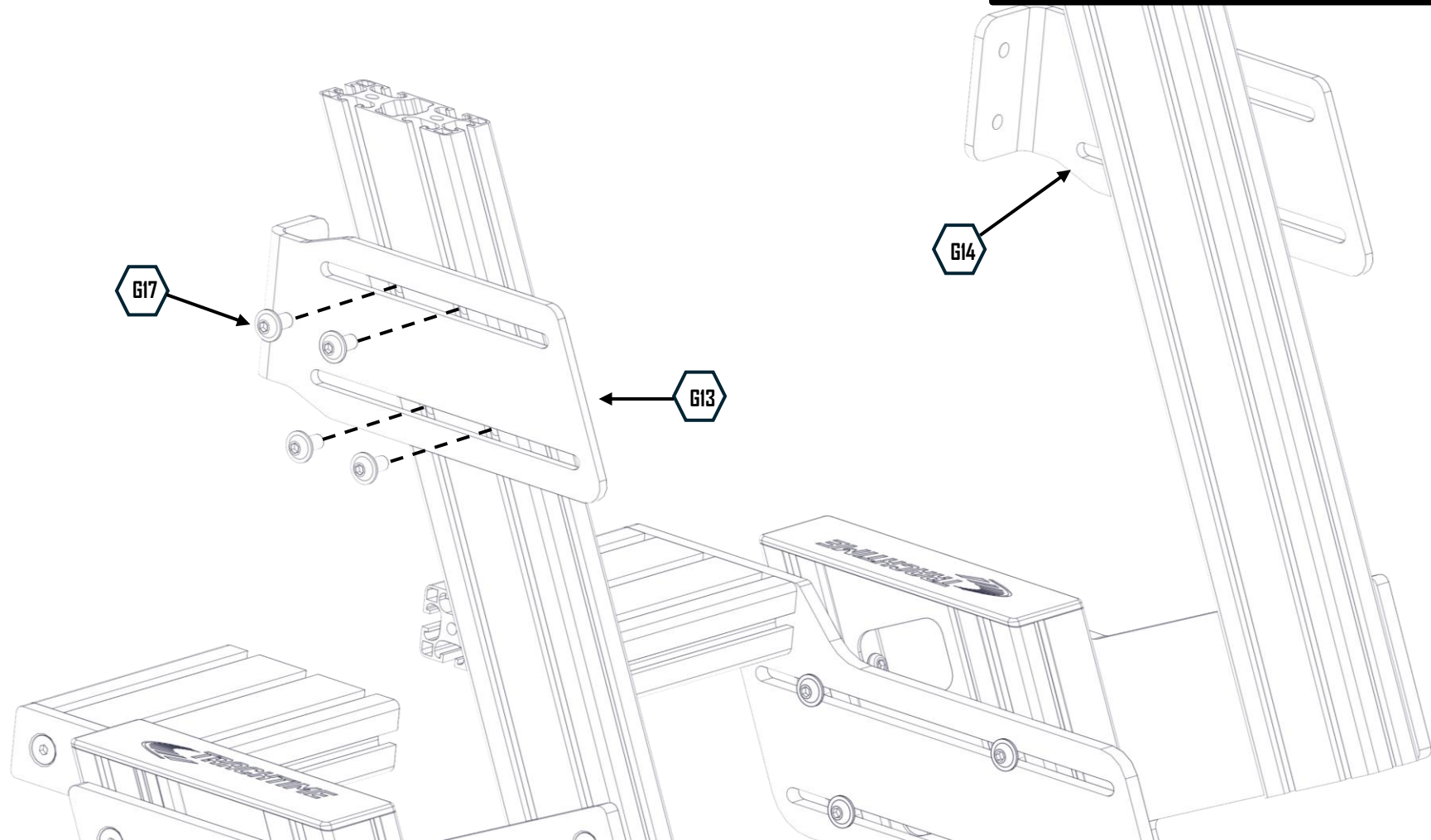



Prepare both brackets (left and right) with (G17) M8x16 screws and (G3) M8 T-nuts.

Only tighten them by one turn so that they can be slid into place in the next step.

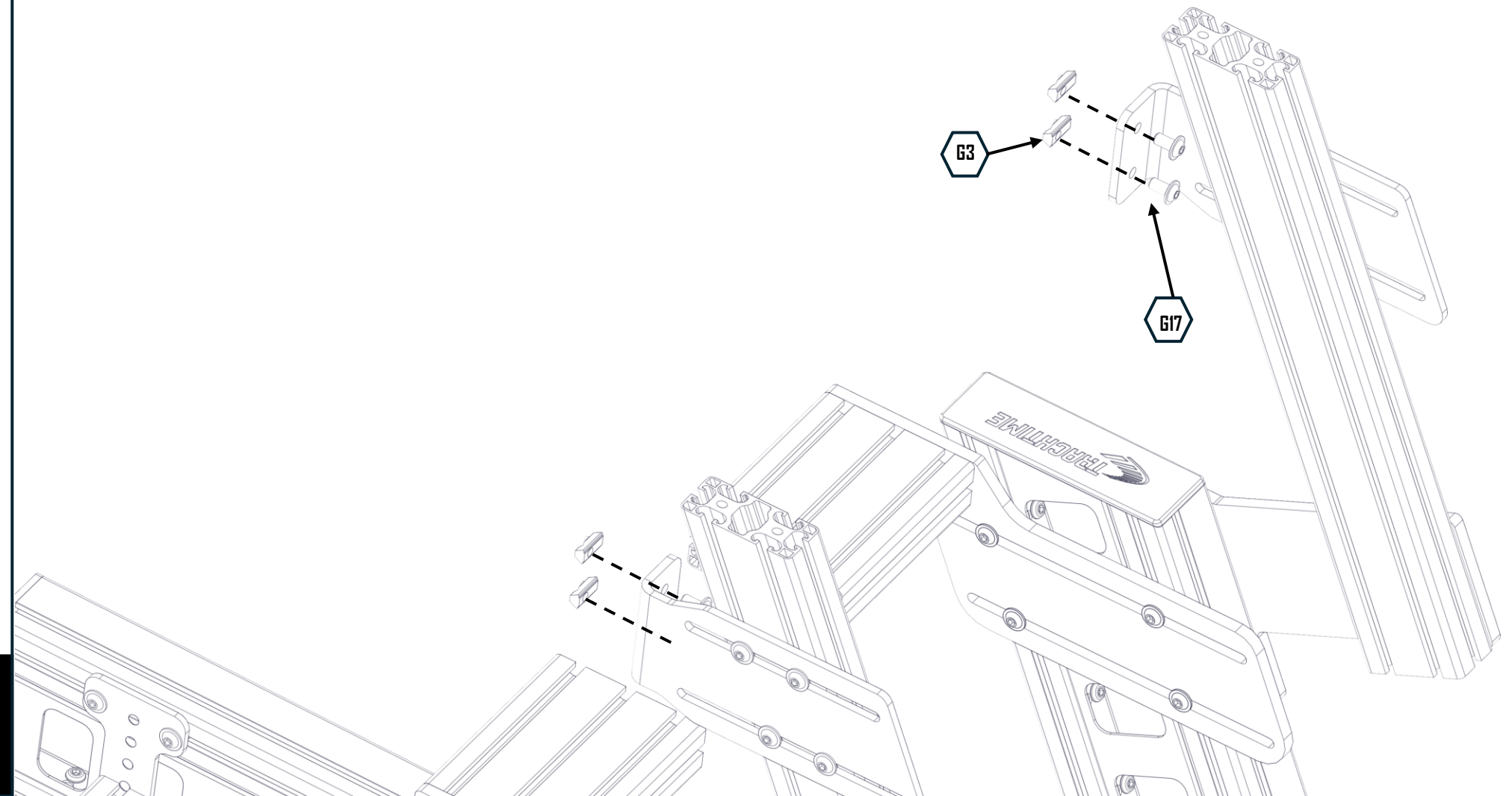

Install the four end caps. Use the (G15) angled version for the upper ends and the (G5) straight version for the lower ends.

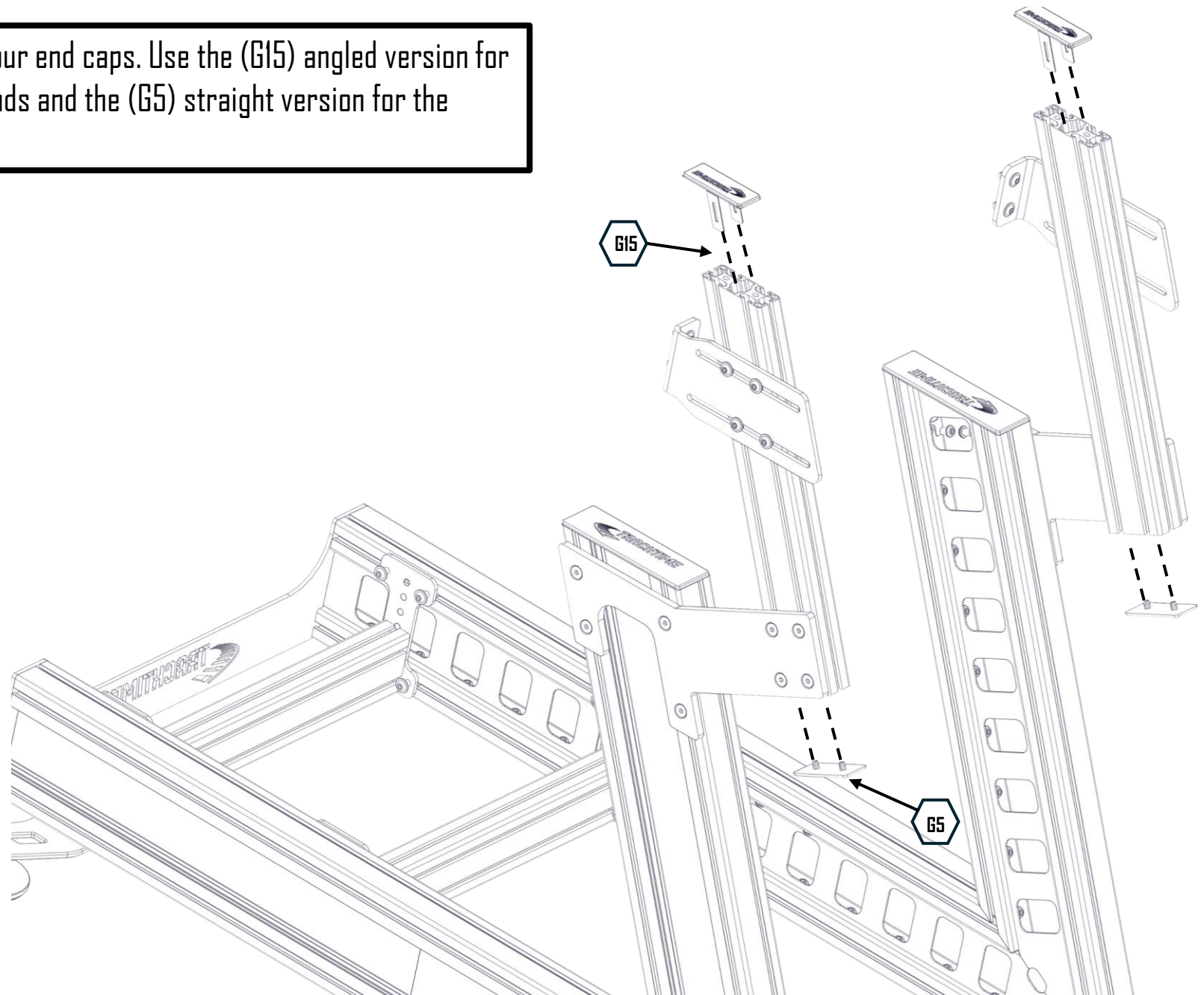
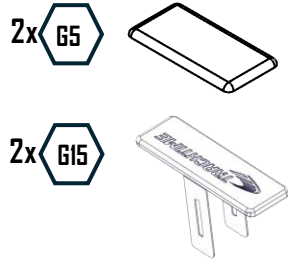

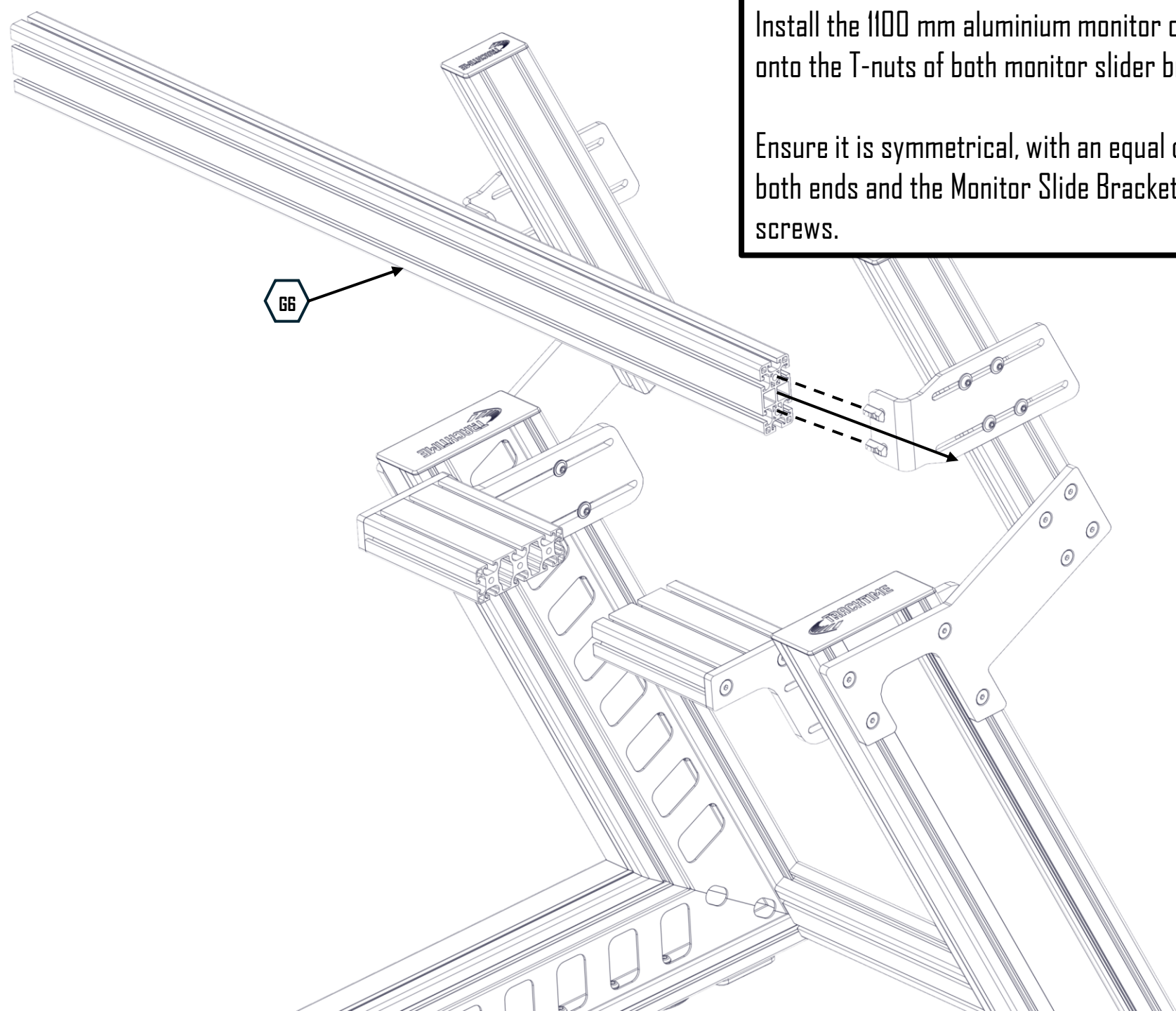

1x 66

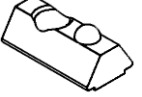

Install the 1100 mm aluminium monitor cross bar. Slide it onto the T-nuts of both monitor slider brackets.

Ensure it is symmetrical, with an equal distance between both ends and the Monitor Slide Brackets. Fasten all four screws.

- 16x G3 
- 16x G4 
- 4x G2 

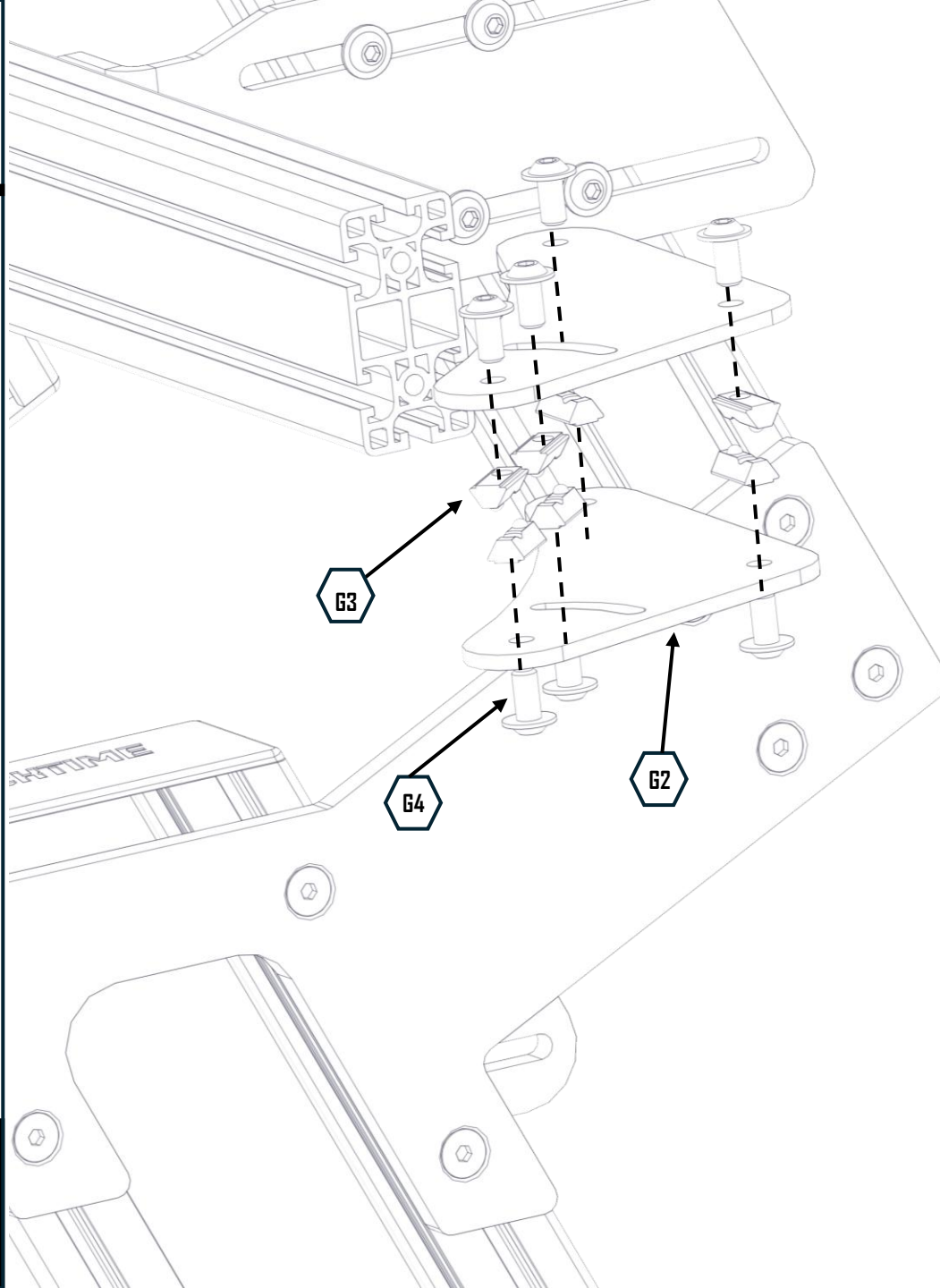

The picture shows the right side.

Create a mirrored version for the left side.

Prepare four Triple Connector Brackets as shown in the picture. Fasten the screws by one turn only. You can then slide them into the monitor cross bar. Refer to Step 10 to see what it should look like once complete.

Step 9 is finished.

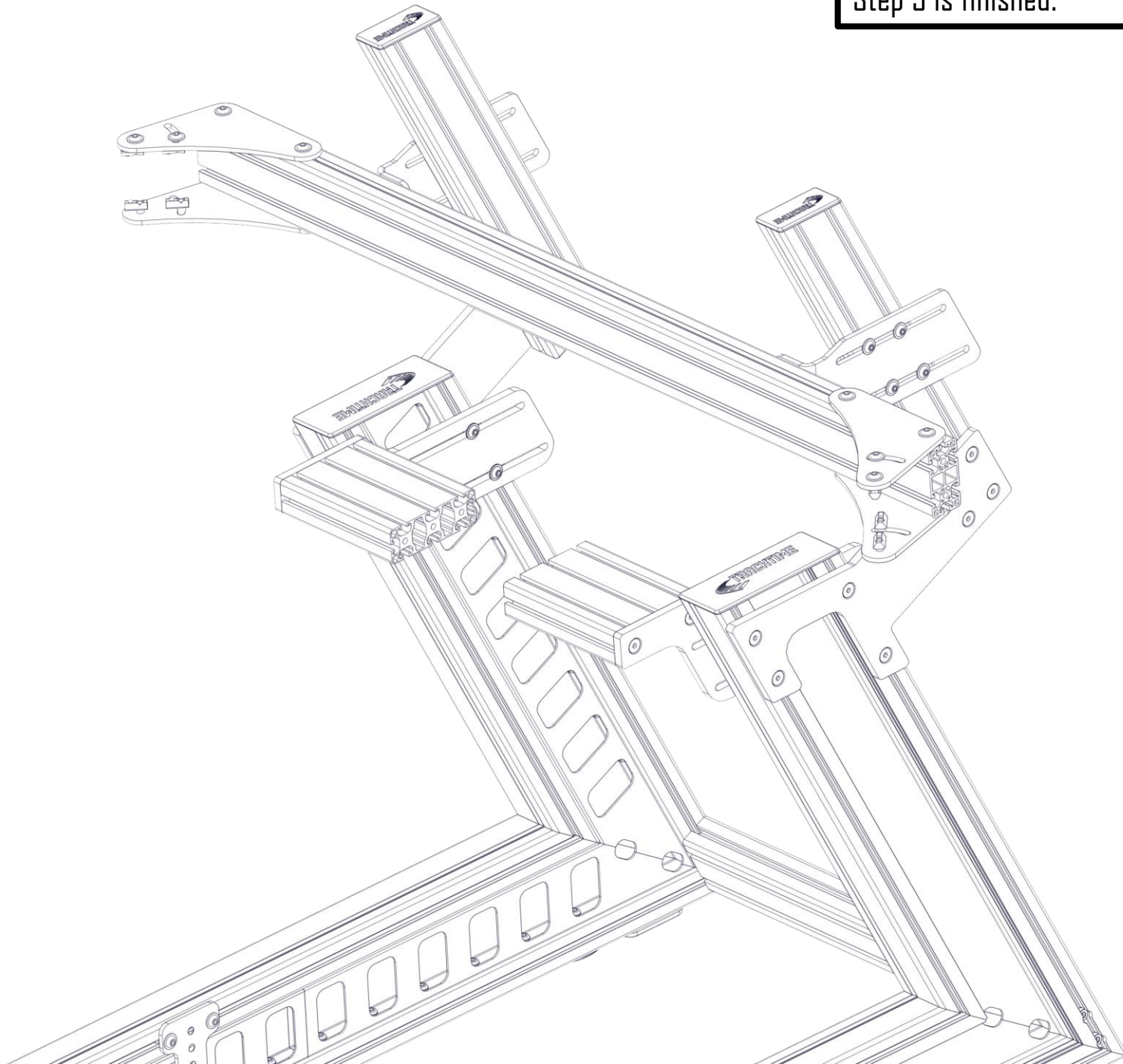

2x GI

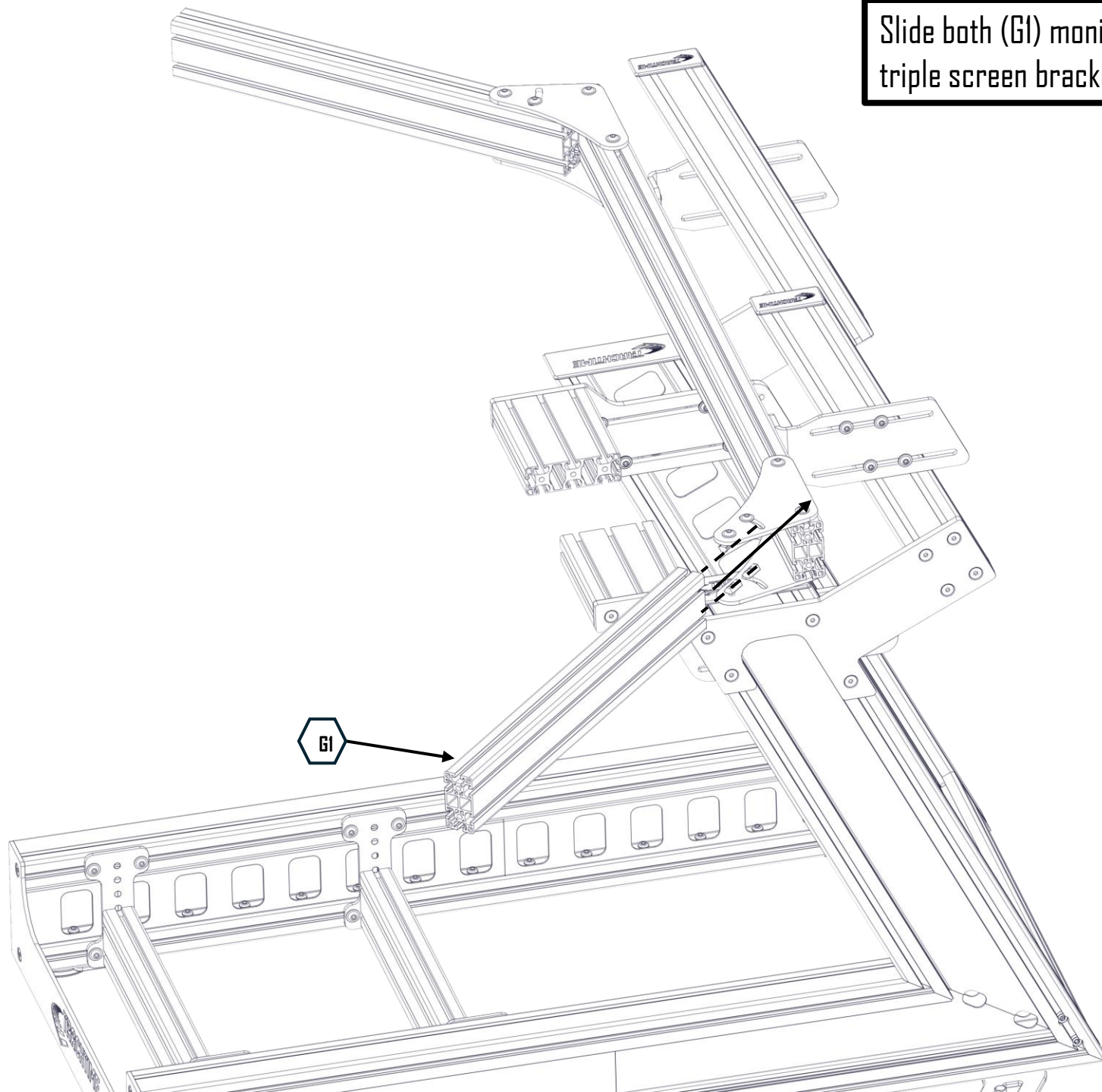

Slide both (GI) monitor side arms onto the prepared triple screen brackets.



Install the four (65) end caps on both sides of the triple screen unit.

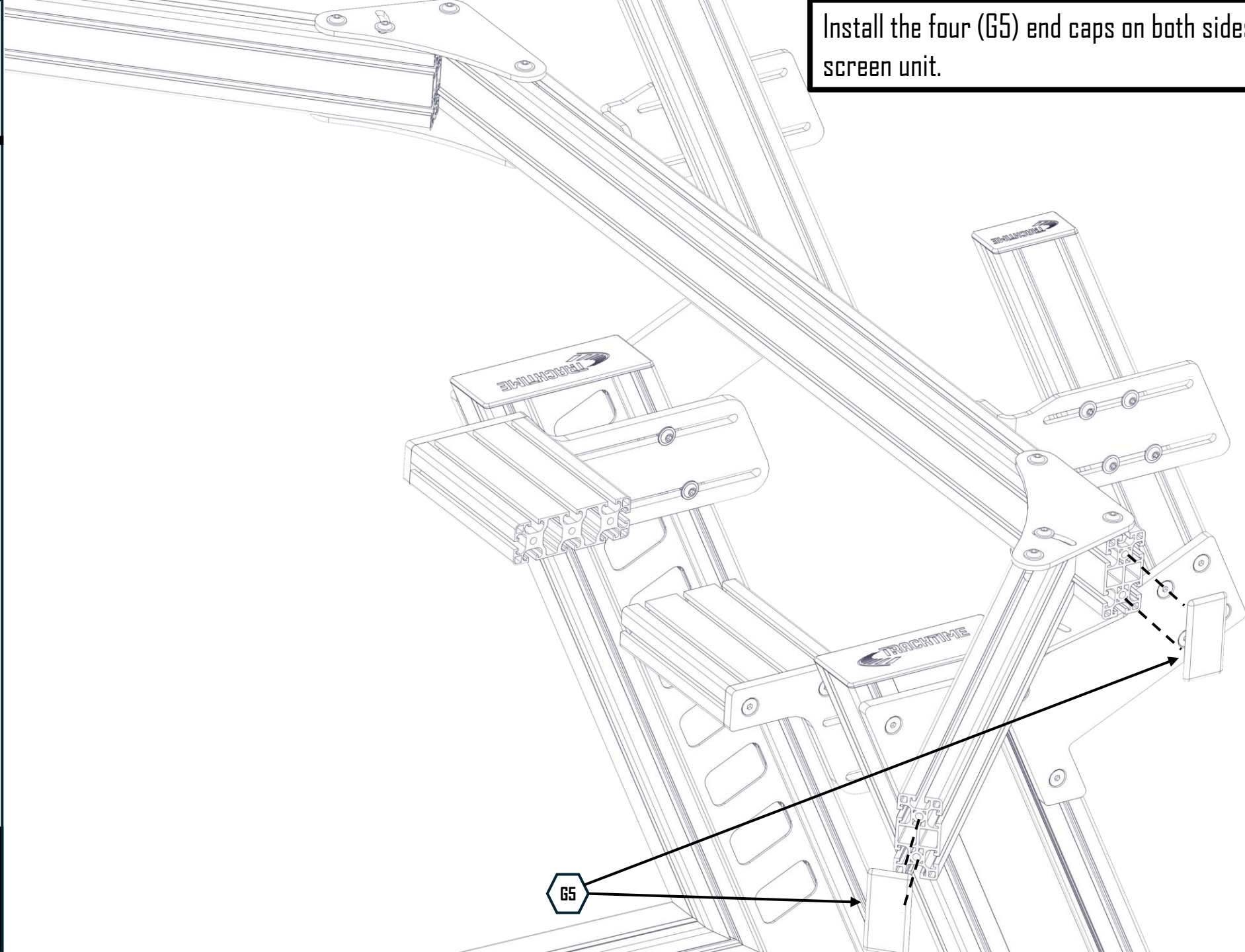

6x G3

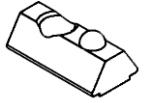

Install six (G3) M8 T-Nuts. Two in each extrusion. Place one in the top back slot of the profile.

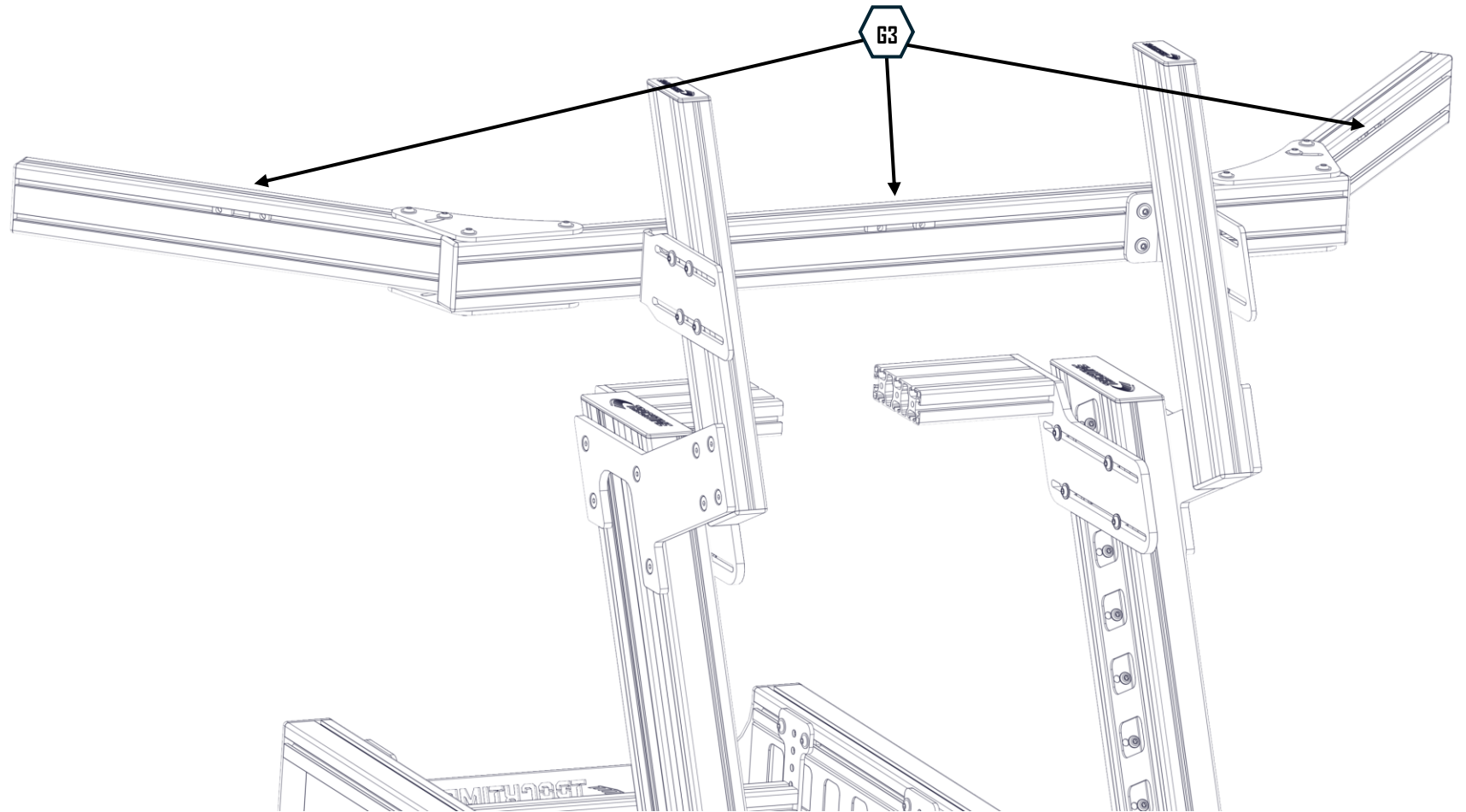

3x 

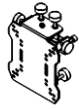

Now read the instructions for the VESA units and remove the 40x40 brackets. Change them to the 80x40 brackets.



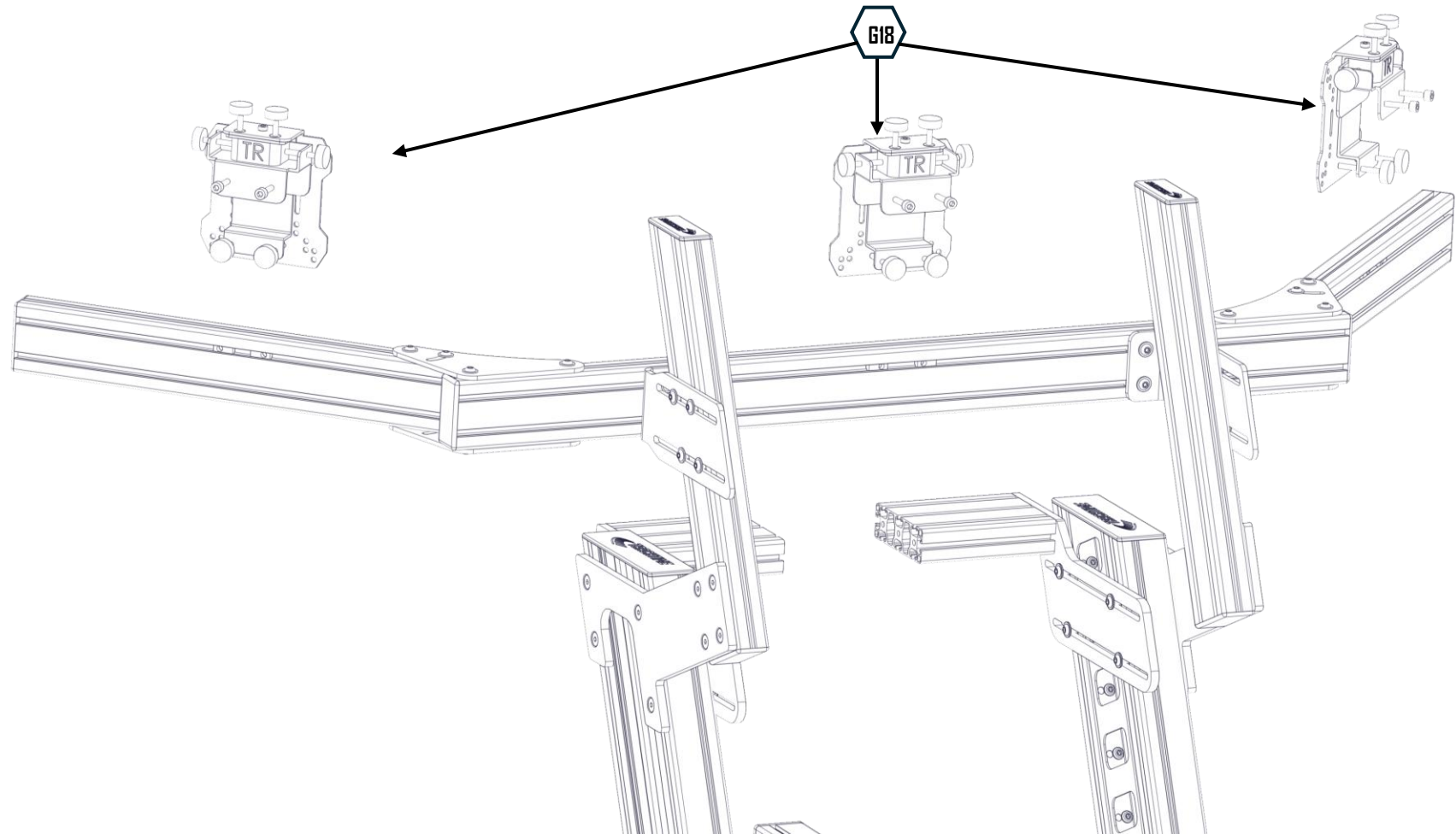

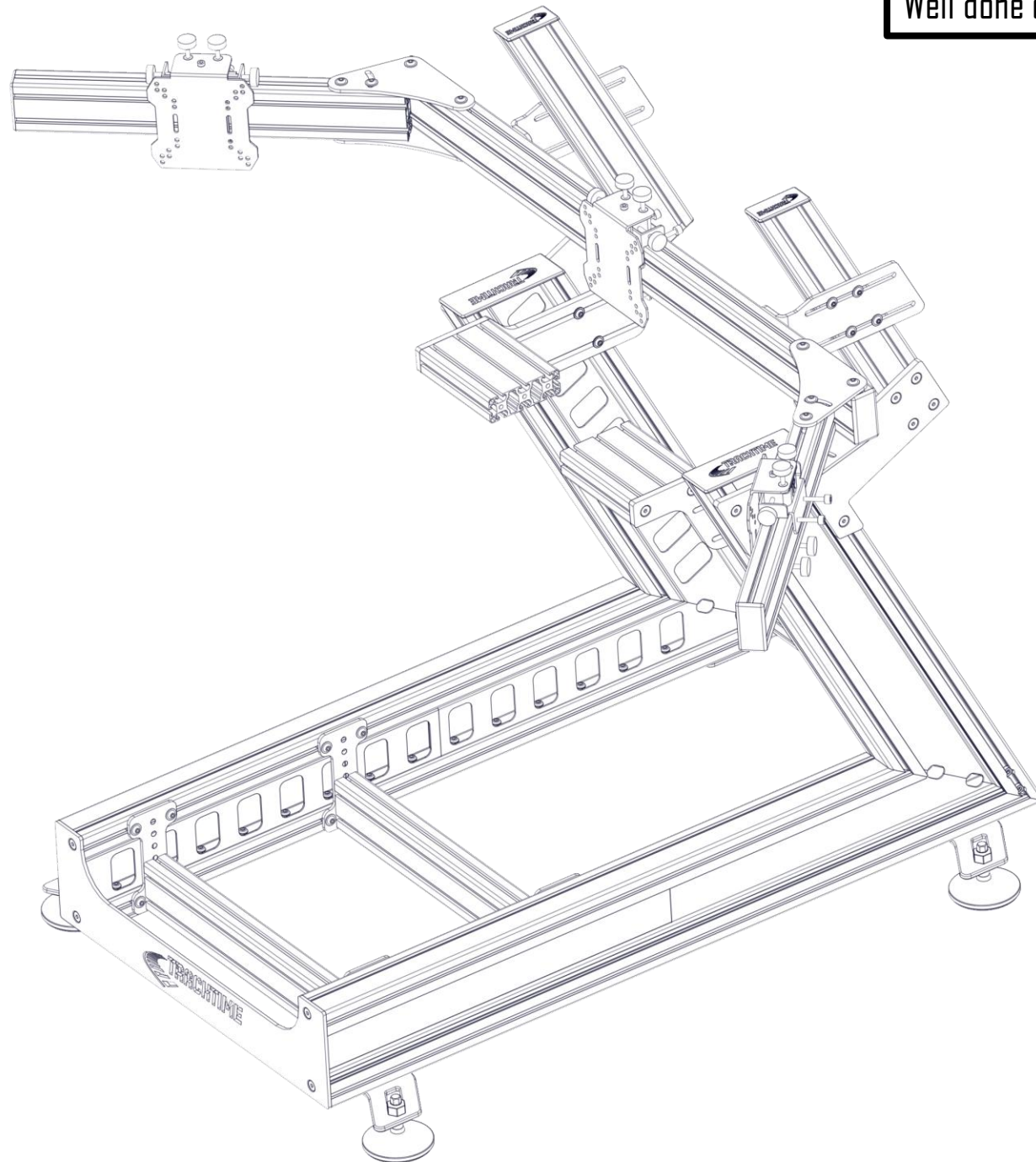

Then, slide one onto each of the extrusions and turn the two mounting screws into the two T-nuts.



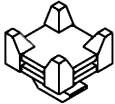

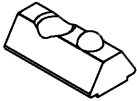
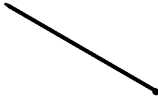

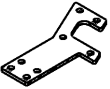
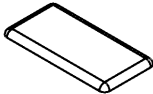
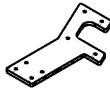

Well done on finishing your Triple Screen Unit!



75105661 Triple Screen Mount

Part	Picture	Order. No.	Article	Pieces	Part	Picture	Order. No.	Article	Pieces
G1		75121195	Monitor Side Bar Aluminium Extrusion 80x40 550mm	2	G7		75130131	Cable Tie Block	6
G2		75121196	Triple Connector Bracket	5	G8		75190068	Cable Management Tubing 3m	1
G3		75190016	T-Nut M8	50	G9		67020001	Cable Tie	10
G4		68320244	Lensflatscrew M8x16	16	G10		75121129	Monitormainbracket left	1
G5		75190018	Extrusion Cap 80x40	6	G11		75121130	Monitormainbracket right	1
G6		75121176	Monitor Center Bar Aluminium Extrusion 80x40 1100mm	1	G12		75121132	Monitor Up Aluminium Extrusion 80x40 500mm	2

75105661 Triple Screen Mount

Part	Picture	Order. No.	Article	Pieces
G13		75121127	Monitor Slider Bracket left	1
G14		75121128	Monitor Slider Bracket right	1
G15		75130319	Angled Extrusion Cap 80x40	2
G16		68320617	Countersunkscrew M8x20	16
G17		68320084	Lensscrew M8x16	12
G18		76036006	VESA Bracket	3

Need help? Scan for help & resources

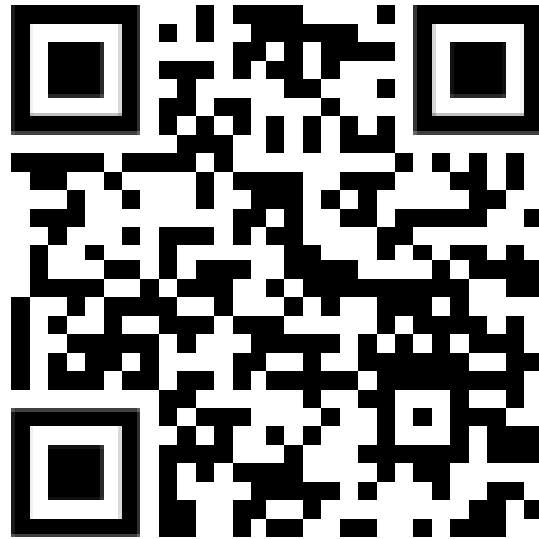

If you have any further questions about assembling this product or about the manual itself, please contact our support department. You can reach them at

info@track-time.de